



ISTITUTO NAZIONALE DI RICERCA METROLOGICA Repository Istituzionale

Asynchronous Phase Comparator for Characterization of Devices for PMUs Calibrator

This is the author's accepted version of the contribution published as:

Original

Asynchronous Phase Comparator for Characterization of Devices for PMUs Calibrator / Trinchera, B.; Serazio, D.; Pogliano, U.. - In: IEEE TRANSACTIONS ON INSTRUMENTATION AND MEASUREMENT. - ISSN 0018-9456. - 66:6(2017), pp. 1139-1145. [10.1109/TIM.2017.2648598]

Availability:

This version is available at: 11696/67872 since: 2021-05-01T17:00:29Z

Publisher:

IEEE

Published

DOI:10.1109/TIM.2017.2648598

Terms of use:

This article is made available under terms and conditions as specified in the corresponding bibliographic description in the repository

Publisher copyright

IEEE

© 20XX IEEE. Personal use of this material is permitted. Permission from IEEE must be obtained for all other uses, in any current or future media, including reprinting/republishing this material for advertising or promotional purposes, creating new collective works, for resale or redistribution to servers or lists, or reuse of any copyrighted component of this work in other works

(Article begins on next page)

Asynchronous Phase Comparator for Characterization of Devices for PMUs Calibrator

Bruno Trinchera, Danilo Serazio, and Umberto Pogliano

Abstract—This paper reports recent progress in developing a new asynchronous digital phase comparator for the precision measurement of phase difference of voltage ratio devices and calibration of functional elements of PMUs calibrator. The phase error of the proposed digital comparator is below 300 nrad at 50 Hz and 100 μ rad at 100 kHz with applied voltages ranging between 500 mV and 3 V, whereas the phase error of cables and connectors was estimated to be 4 μ rad at 1 MHz. Besides resistive dividers, the phase comparator has been employed for the characterization of frequency behavior of phase difference between the output and input of voltage and transconductance amplifiers for a PMUs calibrator. The system can also be an important tool for phase-frequency characterization of devices employed for specific wideband power measurements.

Index Terms—Phase comparators, analog-digital conversion, phasor measurement units, measurement standards, resistive voltage dividers.

I. INTRODUCTION

RELIABLE and synchronized amplitude and phase measurements of synchrophasors in different points of the grid are crucial for power grid state estimation. Phasor measurement units (PMUs), synchronized to a common time reference, e.g., provided by the GPS system, are employed for these real-time synchrophasors measurements. In order to perform these measurements at the best level of accuracy, PMUs need accurate calibration in terms of both amplitude and phase, under static and dynamic regime, and this can be accomplished on-site by calibrated PMUs or in laboratory by dedicated PMUs calibrators [1], which must be in turn traceable to suitable known reference standards maintained by National Metrology Institutes (NMIs).

We developed techniques for traceable measurements of phase difference of active and passive components suitable to be assembled in a PMUs calibrator. These techniques were extended well beyond the power frequency range to include possible analysis of high order harmonics and dynamic behavior of PMUs.

As a basic tool for this work a new asynchronous digital

phase comparator (ADPC) was developed, which is an extended version of [2]. Its use is intended for precision measurement of phase error at various frequencies of passive and active devices employed in PMUs calibrator, as reported in [3]. A similar phase comparator system operating from 500 Hz up to 100 kHz [4] was realized for phase error measurements of high current shunts [5] and its intrinsic phase error was determined by means of a FPGA-DAC based dual synthesizer [6] having 96 dB of spurious free dynamic range (SFDR).

The paper is structured as follows. Next section describes in general the structure of the asynchronous digital phase comparator and the experimental method adopted for phase error measurement. Section III gives an overview on passive standards and active amplifiers for a PMU calibration system. The general approach for phase error calibration of voltage and current amplifiers using passive devices as phase standards is explained in more details in section IV. Finally, the experimental results on the characterization of the ADPC, passive transducers, TA and TV amplifiers with the relative uncertainty budgeted are given in section V.

II. ASYNCHRONOUS DIGITAL PHASE COMPARATOR

A. Experimental setup

The ADPC is based on a commercially available flexible-resolution analog-to-digital converter (ADC)¹ with two-simultaneously sampled channels CH1 and CH2, and an embedded PC controller (PXI-CPU) with real-time operating system, both inserted within a wideband PXI-chassis². An AC calibrator supplies single-tone waveforms to the channels of the comparator by means of a short coaxial T-cable. A block diagram of the comparator is reported in Fig. 1.

The phase-frequency scanning procedure, $\Delta\phi = f(v)$, is performed by means of a closed-loop algorithm developed in LabWindowsTM/CVI. The data are sampled simultaneously by the two channels of the comparator and computed with a four-parameter sine fit algorithm, which is the same employed in a previous digital phase comparator setup for high current

Manuscript received July 10, 2016; revised month date, year; accepted month date, year.

The authors are with the Istituto Nazionale di Ricerca Metrologica (INRiM), Strada delle Cacce 91, 10135-Turin, Italy (e-mail: b.trinchera@inrim.it).

¹ PXI-5922 - National Instrument, with vertical resolution from 24-bits at 500 kS/s to 16-bits at 15 MS/s.

² NI PXIe-1085 24 GB/s chassis - National Instrument.

The manufactures and the types and instrumentation mentioned in this paper do not indicate any preference by the authors nor does it indicate that these are the best available for the application proposed.

shunts [4].

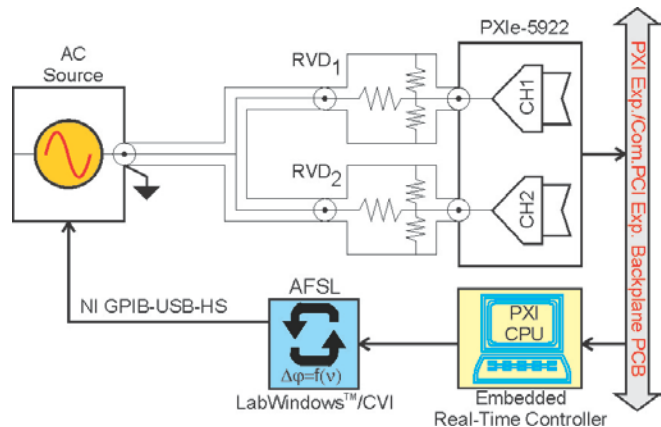

Fig. 1. Basic block diagram of the asynchronous digital phase comparator and an example of its implementation for the phase comparison of coaxial resistive voltage dividers, RVD₁ and RVD₂, up to 1 MHz.

B. Measurement procedure and equations

The phase difference of the devices under comparisons is extrapolated by two set of measurements. The system of equations for direct and reverse difference phase measurements is

$$\begin{cases} \varphi^X - \varphi^S = \Delta\phi^D + \epsilon \\ \varphi^S - \varphi^X = \Delta\phi^R + \epsilon \end{cases} \quad (1)$$

where φ^X and φ^S are the absolute phase errors of the devices under comparison, $\Delta\phi^D$ and $\Delta\phi^R$ are the measured quantities in the direct and reverse conditions and ϵ is the error of the measurement system.

By subtracting and adding the equations of system (1), two new equations are obtained:

$$\varphi^X - \varphi^S = (\Delta\phi^D - \Delta\phi^R)/2 \quad (2)$$

and

$$\epsilon = -(\Delta\phi^D + \Delta\phi^R)/2 \quad (3)$$

where (2) allows us to compute the phase error of the unknown standard φ^X in terms of phase error of the reference standard φ^S and a set of measurements ($\Delta\phi^D$ and $\Delta\phi^R$), whereas (3) links the error of the measurement system to the same set of measurements.

In fact, two measurements are necessary to extrapolate the relative phase difference and to compensate for the systematic error of the system.

Fig. 2 reports schematically the two measurement steps, namely: i) direct measurement (D), performed by connecting the output of RVD₁ and RVD₂ to the respective inputs S₁ and S₂ of the ADPC, and ii) for reverse measurement (R), performed by exchanging the RVDs outputs with respect to the ADPC inputs.

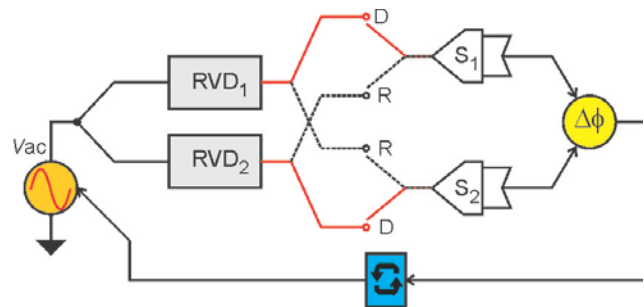

Fig. 2. Scheme of the measurement procedure for characterization of the phase error of resistive voltage dividers for frequencies up to 1 MHz.

III. TRANSDUCERS AND AMPLIFIERS OF THE PMU CALIBRATOR

A. Precision transducers: coaxial RVDs and high current shunts

Passive transducers, i.e. coaxial resistive dividers (RVDs) and high current shunts, are generally employed for precision characterization of voltage and current amplifiers for a PMU calibration system under static and dynamic conditions.

A new set of coaxial resistive voltage dividers (RVDs) with nominal ratio of 1:3, 1:10 and 1:26 was constructed by using surface mounting high precision metal film resistors having nominal value of 1 k Ω and 10 k Ω , respectively, 0.01 % of tolerance and low temperature coefficient (0.2 ppm/ $^{\circ}$ C). Fig. 3 shows the set of RVDs realized at INRIM.



Fig. 3. New set of wideband coaxial resistive dividers for voltages ranging from 1 V to 150 V and frequencies up to 1 MHz. Construction details of 1:52 ratio RVD are given in [7].

The overall structure of the RVDs was made as simple as possible and enclosed in a small metallic box that acts as a coaxial screen. In particular, suitable compensation techniques [7]–[10] were adopted for reducing their input-output phase error. A variable capacitor was connected in parallel to the output of the RVDs in order to compensate the phase error due to the loading effect at a specific frequency.

Besides to the resistive dividers, current shunts are used as precision transducers for the calibration of transconductance

amplifiers. They are generally characterized by high stability impedance with the variation of the current, temperature and time. Two technologies are prevalently used and commercialized: the so-called cage designs [10], [11], where a number of resistive elements are connected in parallel, in a cage-like design and coaxial foil structures employing resistive metal alloys arranged in coaxial structures [12], [13], oriented at minimising their inductance.

A further shunt technology with low ac-dc current transfer difference has been built specifically at INRIM for currents ranging from 20 mA to 7 A [14]. In particular, they are assembled on a disk by connecting in parallel precision resistors, so the effects of the inductance in the input circuit and of the mutual inductance between the input and the output are reduced. Fig. 4 shows the set of current shunts built at INRIM.



Fig. 4. Set of coaxial shunts built at INRIM and employed for primary alternating current scale realization and as phase standard for currents from 20 mA up to 7 A and frequencies up to 100 kHz.

The circuitual model of these shunts is a two port transresistance and the parameters of interest for the measurements are the transresistance ratio and the phase difference between output voltage and input current. In particular, their phase difference between output voltage and input current was determined by means of a wideband digital phase comparator [4]. Its use is intended for currents ranging from 2 A to 100 A and frequencies from 500 Hz to 100 kHz [5]. Since the phase comparator performs relative phase measurements between current shunts under comparison, it is essential that the phase error of one of the shunts under comparison must be known. A particular shunt based on a disk resistor was constructed as reference for the absolute value of the phase. Its phase was assumed to be zero in the whole frequency band and the shunts are compared at increasing currents by a step-up procedure. For higher frequencies (e.g. 100 kHz) the phase difference increases approximately linearly with the frequency. The expanded uncertainty ($k = 2$) was evaluated in [4], [5] and [15] and is lower than 500 $\mu\text{rad/rad}$ at 100 kHz.

B. Voltage and current amplifiers

Accurate amplifiers are often used for the construction of a PMU calibration system, as for example in the calibrator described in [3] and [16]. These amplifiers, which can be

either voltage amplifiers (VA) for the voltage channels or transconductance amplifiers (TA) for the current channels, adjust to the proper level the signal produced by the DACs of the basic signal generator locked to the time reference. The construction of these amplifiers requires both active components to amplify the signals and passive components, which are usually employed in feedback configuration. A picture of the experimental setup employed for the phase error characterization of VA and TA using the ADPC system is reported in Fig. 5.

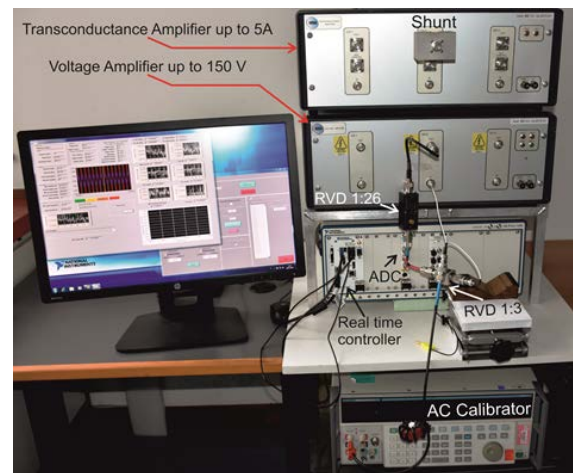

Fig. 5. Photo of the experimental setup based on an automatic asynchronous digital phase comparator for phase characterization of passive and active devices. The voltage and transconductance amplifiers are three-channels amplifiers designed for a PMUs calibration system.

Resistive or inductive elements that establish the correct value of a ratio between the output voltage and the input voltage can be employed for these amplifiers. Inductive dividers are intrinsically more accurate for setting the ratio of sinusoidal voltage signals at intermediate frequency, but they are more difficult to insert in a feedback control system for wideband signals. So, resistive dividers are preferred for wideband amplifiers because they can be characterized in a wider band and deliver fast response, necessary to reduce the phase difference between output and input signals. Furthermore, the resistive dividers can deal with the dc components and their ratio may be accurately characterized in terms of ac-dc transfer difference. The specifications of a voltage amplifiers are always a compromise between different requirements. The fast response is, for example, obtained at the cost of reduction of the dynamic stability and of the noise rejection.

In the transconductance amplifiers the passive components used as internal reference are shunts or current transformers connected to shunts. A shunt used in the feedback of a channel of an amplifier set the ratio of between the output current and the input voltage. Shunts, for higher currents have reactive components that increase the gain errors. The frequency band of operational amplifiers or other electronic components for higher currents have a limited frequency band, which underline some problems for the stability of the instruments.

IV. A METHOD FOR THE PHASE ERROR CALIBRATION OF VOLTAGE AND TRANSCONDUCTANCE AMPLIFIERS

Voltage and transconductance amplifiers are often critical elements of a PMUs calibrator, because they introduce not negligible gain errors both as amplitude and phase. To improve the accuracy of a PMUs calibrator chains an accurate calibration process of the gain is necessary to characterise the amplifiers and implement procedures for their correction. INRIM developed a method for precise phase calibration of passive and active devices for a PMU calibrator, even if for the calibration of the gain amplitude an equivalent procedure can be investigated.

Passive transducers, i.e. RVDs and current shunts, are useful for scaling down high voltages and for sensing high currents in terms of voltage drop across the resistive elements. The output voltage of transducers should be at the same level and that complies at least with the full scale input range of the synchronized digitizers. One of the main peculiarities of passive transducers is the long-term stability of their phase characteristics and, if well balanced, a reduced sensitivity to external conditions. Specifically, in the passive elements the phase rotation depends on structure and on the reactive and resistive components.

The method proposed in this paper for the characterization of the amplifiers involves the comparison between the input and the output of each amplifier and assumes that both input-output ports of single channels of the amplifier under test are accessible. The use of suitable and well-characterised transducers allows us to specifically scale down and convert the output levels of voltage and current amplifiers to the level of the input specification of the phase comparator.

The block diagrams of the experimental setups employed for phase characterization of voltage and current amplifiers using passive devices, previously calibrated in phase, are reported in Fig. 6(a) and Fig. 6(b).

The input of the amplifier under test and the output of the passive element are then connected to the two channels of the phase detector and, as they are now homogeneous quantities of similar range, they can be interchanged for compensating possible systematic errors in the phase detector and in the connection cables.

By supplying sinusoidal signals to the input of an amplifier the phase difference for every frequency of interest can be evaluated and the linearity can be verified using different amplitudes. As the phase difference introduced by the shunt or the voltage divider is known by the characterisation of the passive transducers it can be taken into account and corrected.

By means of the determination of the amplitude and phase difference between the input and the output it is possible to identify the frequency plot of the complex gain of the amplifier. Moreover additional parameters as the slew-rate or the non-linearity of the gain could be measured by using different waveforms from the sinusoidal ones.

The estimation of the parameters depends on the model of the system taken into consideration. There are several approaches for building a model of an amplifier. In case of a process perfectly known, for example, the model can be built

accurately from these specific physical characteristics that can be translated into the relevant equations. When the model is unknown the identification must be only based on some recorded sequences of the input and the output. An intermediate case is the knowledge of the class of amplifiers considered (for example bandpass amplifiers) and the possibility to decide the input to be supplied to the system under test.

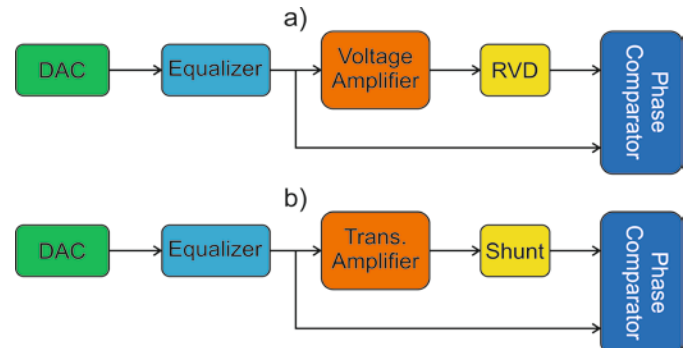

Fig. 6. Schematic blocks for frequency characterization of input-output characteristic of voltage amplifier a) and transconductance amplifier b) in terms of phase by using calibrated passive devices RVD and current shunt with well-known phase error.

The starting point can be a simple linear system adding then non-linearity and saturation of the internal states (for example the slew-rate in the amplifiers). If the internal structure is known or can be easily assumed a convenient representation can be given by means of the state equations. The advantage is the possibility, extremely realistic in an amplifier, to introduce saturation of one or more states and to analyse and easily model the main cause of not linearity.

V. EXPERIMENTAL RESULTS

The new phase comparator was widely employed for phase calibration of a set of RVDs transducers and voltage and current amplifiers to be used for PMUs calibrator realization. All the characterization were performed by keeping the main parameters of the digital phase comparator constant. In particular the sampling frequency of the digitizers and the number of the acquired points have been set respectively to 10 MS/s and 6×10^6 samples per channel, respectively. The equivalent aperture time of the sampler is set to 1.6 s.

A. Phase difference of the digitizer

The first step in the phase calibration of passive and active devices consists in the characterization of the phase difference between the channels of the digitizer, which is performed by applying the same voltage through a voltage node to both channels keeping the main parameters of the digitizers as the sampling frequency, the vertical resolution, the trigger level and the recording length constants. Fig. 7 reports the phase difference of ADPC measuring system characterized at different input applied voltages and frequencies ranging from 20 Hz to 1 MHz. All measurements were carried out maintaining unchanged cables end connectors. In particular, the phase error of cables and connectors was measured to be

4 μrad at 1 MHz.

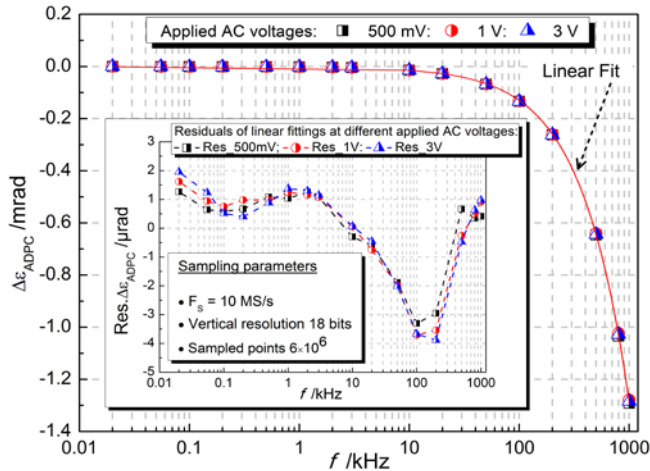

Fig. 7. Behavior at various applied AC voltages and frequencies of the phase difference of asynchronous digital phase comparator and the set of cables and connectors, $\Delta\epsilon_{ADPC}$, employed during the measurement process. The inside inset shows the residuals of the liner fittings.

B. Step-up procedure for the phase error calibration of RVDs

Fig. 8 shows the results of the step-up procedure employed for the calibration of phase angle error of the set RVDs. They were first compensated finely at a fixed frequency, of about 10 kHz, and successively characterized up to 1 MHz.

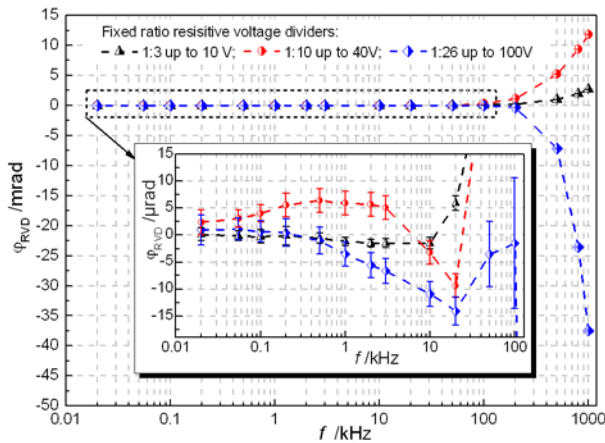

Fig. 8. Phase error of the RVDs determined by the step-up procedure. The 1:3 RVD was calibrated at 3 V, then it was used at 3V and 10 V for the calibration of the 1:10 RVD. Finally, the 1:10 RVD was used at 10 V and at 30 V for the calibration of the RVD with rated ratio 1:26.

The first step of the step-up procedure consists in the determination of the phase error of the RVD with 1:3 nominal ratio, which was determined directly against the ADPC system for voltages ranging between 1 V up to 3 V. Its phase error is minimized at 10 kHz by finely trimming a variable shunt capacitance connected in parallel to its output. The same phase compensation procedure has been adopted for all RVDs employed in the step-up procedure by keeping cables and connectors unchanged.

Moreover, for our convenience and better stability, the shunt capacitor of the high-ratio RVDs was split in two

parallel capacitors: the first one is a precision surface mounting capacitor with temperature compensated dielectric; the later one is a trimmer capacitor variable up to 10 pF. We assume that during the step-up procedure the RVD does not change its phase error between the voltage level at which it is calibrated and its nominal voltage level.

Furthermore, test signals different from the sinusoidal ones (for example step or pulse signals) can also be used to identify non linearity problems (i.e. slew rate) that affect the dynamic behaviour of the amplifiers.

C. Phase angle error characterization of VA and TA

The characterization of phase angle error of the voltage amplifier (VA) was performed according to the method described in section IV. The gain of the voltage amplifier is fixed to 20 V/V. Its input is supplied by an alternating voltage at various frequencies provided by a voltage calibrator model J. Fluke mod. 5720A, which is remotely controlled by the ADPC software. The measurement procedure is handled automatically by taking constant the voltage output of the calibrator and varying its frequency from 20 Hz up to 200 kHz. At each frequency, after a stabilization time fixed to 20 s, the ADPC acquires the waveforms and computes the phase difference.

In particular, for voltages higher than 80 V an additional reference RVD, e.g. with lower nominal ratio 1:3, was inserted in order to prevent saturation of the input of the phase comparator. The high voltage output of the VA was scaled down by means of a RVD with nominal ratio of 1:26. Due to the bandwidth constrains of the VA, its phase error was characterized up to 200 kHz.

Fig. 9 reports the results of the phase angle error characterization of the VA amplifier performed at 75 % of its full working range, i.e. at 100 V.

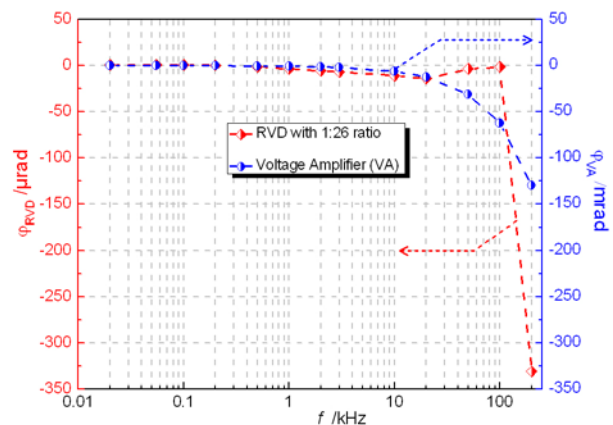

Fig. 9. Phase angle error of the voltage amplifier and RVD of 1:26 ratio as a function of the frequency. The gain of the VA is set to 20 and applied AC voltage is 5 V.

The phase angle error of the TA was characterized by means of a shunt using the scheme of the Fig. 6(b). The series of the TA and the shunt was supplied by a 2 V signal generated by a J. Fluke mod. 5720A calibrator at different

frequencies. The input and output voltages were evaluated by the phase comparator.

As the phase angle error of current shunts was calibrated only at specific frequencies, i.e. from 500 Hz to 100 kHz, a linear regression was applied for its evaluation for frequencies ranging from 50 Hz to 500 Hz. The expanded uncertainty at each frequency of interest was derived by the linear regression and by uncertainty evaluation at the each frequency where the measurements were performed.

The phase angle errors of the TA and that of the current shunt employed as phase standard during the characterization of the TA at different frequencies are shown in Fig. 10.

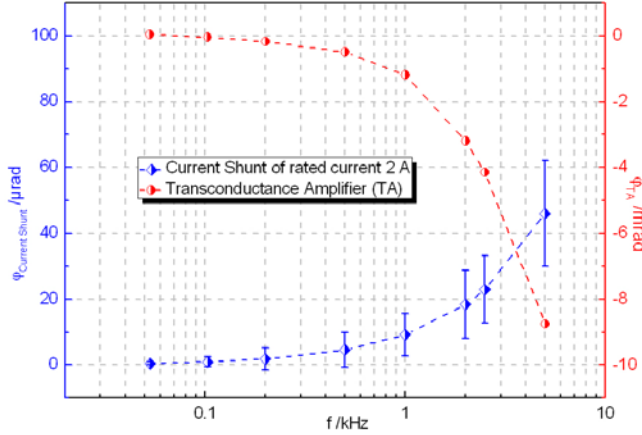

Fig. 10. Phase angle error of the transconductance amplifier (TA) and of the current shunt employed as phase standard as a function of the frequency. The transconductance of the TA was set to 1 S and the applied AC voltage was 2 V.

D. Uncertainty calculations

The measurement uncertainties of the phase difference between output and input of an amplifier can be evaluated from the uncertainty components of the phase comparator and devices employed in the experimental setup at various frequencies.

Table I and II summarize the components of uncertainty for the phase difference measurements of voltage and transconductance amplifiers. The main components of the uncertainty are the following:

- $u(\varphi_{ADPC})$, uncertainty of the phase comparator given by the combination of the difference between the delays of the two comparator channels, cables, connectors and level dependence during the step-up procedure (more details are reported in [4]).
- $u(\varphi_{RVD\ 1:3})$, $u(\varphi_{RVD\ 1:26})$, $u(\varphi_{Shunt})$, uncertainties of the phase standards employed in the experiment (resistive dividers and current shunts) computed by the step-up procedure.
- $u(\varphi_{Rep.Meas})$, uncertainty of the measurement method computed as $u(\varphi_{Rep.Meas}) = \sqrt{u^2(\phi^D) + u^2(\phi^R)}$, where $u(\phi^D)$ and $u(\phi^R)$ are the uncertainties of repeated measurements in the direct and reverse configuration.

The measurement uncertainties are computed using the square root of the sum of the squares of the contributions with equal weights. The dominant components, in the case of

passive devices, comes from the step-up procedure.

TABLE I

UNCERTAINTY BUDGET FOR MEASUREMENT OF PHASE DIFFERENCE OF THE VOLTAGE AMPLIFIER AT 100 V

Contribution to total uncertainty ($\mu\text{rad}/\text{rad}$)	Standard uncertainty ($\mu\text{rad}/\text{rad}$) at frequency:					
	53 Hz	1 kHz	10 kHz	50 kHz	100 kHz	200 kHz
$u(\varphi_{ADPC})$	0.8	0.3	0.4	2.0	3.0	6
$u(\varphi_{RVD\ 1:3})$	0.8	0.5	0.7	2.3	4.6	9
$u(\varphi_{RVD\ 1:26})$	1.5	0.6	0.9	3.4	7	14
$u(\varphi_{Rep.Meas})$	0.4	0.4	0.6	2.6	4.5	8
Combined standard uncertainty ($\mu\text{rad}/\text{rad}$)	1.9	0.9	1.3	5.4	10	19
Expanded uncertainty ($k=2$) ($\mu\text{rad}/\text{rad}$)	3.8	1.9	2.7	11	20	39

TABLE II

UNCERTAINTY BUDGET FOR MEASUREMENT OF PHASE DIFFERENCE OF THE TRANSCONDUCTANCE AMPLIFIER AT 2 A

Contribution to total uncertainty ($\mu\text{rad}/\text{rad}$)	Standard uncertainty ($\mu\text{rad}/\text{rad}$) at frequency:					
	53 Hz	200 Hz	500 Hz	1 kHz	2 kHz	5 kHz
$u(\varphi_{ADPC})$	0.8	0.6	0.5	0.3	0.4	0.4
$u(\varphi_{Shunt})$	0.5	1.7	2.6	3.2	6.0	8.0
$u(\varphi_{Rep.Meas})$	1.1	1.8	1.6	1.7	3.0	3.8
Combined standard uncertainty ($\mu\text{rad}/\text{rad}$)	1.4	2.7	3.1	3.6	6.7	8.9
Expanded uncertainty ($k=2$) ($\mu\text{rad}/\text{rad}$)	2.9	5.1	6.2	7.3	13	18

I. CONCLUSION

The results reported in section V confirmed the improved capabilities obtained by using the new asynchronous digital phase comparator to measure the phase difference of isofrequency waveforms up to 1 MHz.

The ADPC was first employed in the construction of the traceability of a set of different rated ratios RVDs in terms of phase angle error by using the step-up approach for frequencies ranging from 20 Hz to 1 MHz.

Additionally, a calibration procedure was developed for precision phase angle error measurements of VA and TA by using RVDs and current shunts with traceable input-output phase error in the bandwidth of interests. The VA and TA are intended to be used in the realization of a PMU calibration system. The overall uncertainty measurement by using the ADPC and calibrated passive standards was evaluated for the VA to be below $6\ \mu\text{rad}/\text{rad}$ at 100 V and frequency of 50 kHz, whereas for the TA at 2 A and frequency of 5 kHz was $9\ \mu\text{rad}/\text{rad}$ ($k=1$).

In the future, further measurements are required and detailed investigations will be performed on compensation of ac-dc transfer difference of RVDs, in reference to their use in the framework of metrological application of spectrally pure Josephson ac voltages.

ACKNOWLEDGMENT

This work was supported in part by the European Union within the EMRP project ENG52 SmartGrid II. The EMRP is

jointly funded by the EMRP participating countries within EURAMET and the European Union.

REFERENCES

- [1] Y. Tang, G. N. Stenbakken, and A. Goldstein, "Calibration of a phasor measurement unit at NIST," *IEEE Trans. Instrum. Meas.*, vol. 62, no. 6, pp. 1417 – 1422, Apr. 2005.
- [2] B. Trinchera, D. Serazio, and U. Pogliano, "Asynchronous phase comparator for characterization of devices and PMU calibrator," in *Proc. CPEM Dig.*, Ottawa, Canada, Jul. 2016.
- [3] J. P. Braun and C. Mester, "Reference grade calibrator for the testing of the dynamic behavior of phasor measurement units," in *Proc. CPEM Dig.*, Washington DC, USA, pp. 410 – 411, Jul. 2012.
- [4] U. Pogliano, B. Trinchera, and D. Serazio, "Wideband digital phase comparator for high current shunts," *Metrologia*, vol. 49, pp. 349 – 358, Apr. 2012.
- [5] G. C. Bosco, et al., "Phase comparison of high-current shunts up to 100 kHz," *IEEE Trans. Instrum. Meas.*, vol. 60, no. 7, pp. 2359 – 2365, Jul. 2011.
- [6] B. Trinchera and U. Pogliano, "Polyharmonic digital synthesizer for the calibration of phase sensitive measuring system up to the ultrasonic band," *IEEE Trans. Instrum. Meas.*, vol. 62, no. 6, pp. 1687 – 1692, Jul. 2013.
- [7] U. Pogliano, B. Trinchera, and D. Serazio, "Traceability for accurate resistive dividers," in *Proc. IMEKO TC4*, Benevento, Italy, pp. 937 – 941, Sep. 2014.
- [8] K. E. Rydler, S. Svensson, and V. Tarasso, "Voltage dividers with low phase angle errors for a wideband power measuring system," in *Proc. CPEM Dig.*, Ottawa, Canada, pp. 382 – 383, Jun. 2002.
- [9] I. Budovsky, A. M. Gibbes, and G. M. Hammond, "Voltage divider characterization at frequencies up to 200 kHz," in *Proc. CPEM Dig.*, Sydney, Australia, pp. 662 – 663, May 2000.
- [10] K. Lind, T. Sorsdal, and H. Slinde, "Design, modeling, and verification of high-performance AC–DC current shunts from inexpensive components," *IEEE Trans. Instrum. Meas.*, vol. 57, no. 1, pp. 176 – 181, Jan. 2008.
- [11] K. E. Rydler and V. Tarasso, "Extending AC–DC current transfer measurement to 100 A, 100 kHz," in *Proc. CPEM Dig.*, Broomfield, Colorado, pp. 28 – 29, Jun. 2008.
- [12] M. Garcocz, P. Scheibenreiter, W. Waldmann, and G. Heine, "Expanding the measurement capability for AC-DC Current Transfer at BEV," in *Proc. CPEM Dig.*, London, England, pp.461 – 462, Jun. 2004.
- [13] M. Garcocz, P. Scheibenreiter, G. Heine, and W. Waldmann, "Progress on BEV foil shunts for AC-DC current transfer," in *Proc. CPEM Dig.*, London, England, pp.272 – 273, Aug. 2014.
- [14] U. Pogliano, G. C. Bosco, and D. Serazio, "Coaxial shunt as AC-DC transfer standards of current," *IEEE Trans. Instrum. Meas.*, vol. 58, no. 4, pp. 872 – 877, Apr. 2009.
- [15] U. Pogliano and B. Trinchera, "Uncertainty characterization of two channels digital analyzer as a wideband phase comparator," in *Proc. CPEM Dig.*, Washington DC, USA, pp. 286 – 287, Jul. 2012.
- [16] J. P. Braun and S. Siegenthaler, "Calibration of PMUs with a reference grade calibrator," in *Proc. CPEM Dig.*, Rio de Janeiro, Brazil, pp. 678 – 679, Aug. 2014.



Bruno Trinchera (1973) received the M.Sc. degree in physics from the University of Torino, and the Ph.D. degree in metrology from the Politecnico di Torino, in 2001 and 2007, respectively. Research toward the Ph.D. degree was conducted in the Istituto di Metrologia "Gustavo Colonnetti" (now merged in the Istituto Nazionale di Ricerca Metrologica (INRIM)) on precision radiation thermometry at low temperatures.

He joined the Istituto Nazionale di Ricerca Metrologica (INRIM), Turin, in 2005. His current research interests include precision measurements of ac quantities, ac/dc voltage and current transfer measurements, power quality measurements, impedance measurements with digitally assisted bridges and development and use of AC quantum voltage standards and superconducting electronics for alternating voltage metrology and direct linking of sampled/synthesized voltage measurements to fundamental physical constants.



Danilo Serazio was born in Italy in 1966. He received the technical school degree in 1982 and the high school degree in electronics from I. T. I. S. "A. Avogadro", Turin, in 1999. After being with various companies, he joined the Electrical Metrology Department, Istituto Elettrotecnico Nazionale Galileo Ferraris, now Istituto Nazionale di Ricerca Metrologica (INRIM), in 1995.

At present he is involved in the electrical power measurement and development of mechanical and electrical equipment employed in ac and dc measurements.



Umberto Pogliano was born in Leini, Turin, Italy, in 1950. He received the Dr. Ing. degree in Electronic Engineering in 1975 and the Ph.D degree in metrology in 1987, both from the Politecnico di Torino.

In 1977 he joined the Electrical Metrology Department of the Istituto Elettrotecnico Nazionale "Galileo Ferraris," now Istituto Nazionale di Ricerca Metrologica (INRIM), Turin, where from 2002 to 2007 was responsible for the Electrical Metrology Department.

His research activity has been focused on the modelling of standards, on the development of systems and procedures in the field of precision dc and ac low-frequency measurements. His main interests are in the ac-dc transfer standard, in the ac voltage, current and power measurements, and in the generation, acquisition and reconstruction of electrical signals. Dr. Pogliano is an Italian delegate of Technical Committee 4 of Imeko.