



ISTITUTO NAZIONALE DI RICERCA METROLOGICA Repository Istituzionale

Reliable and Robust UTC(IT) Generation Based on Master and Backup Time Scales
Alignment at INRiM

This is the author's submitted version of the contribution published as:

Original

Reliable and Robust UTC(IT) Generation Based on Master and Backup Time Scales Alignment at INRiM / Signorile, G.; Formichella, V.; Thai, T. T.; Perucca, A.; Cantoni, E.; Sellone, M.; Mura, A.; Siccardi, M.; Rovera, G. D.; Sesia, I.; Levi, F.. - (2019), pp. 463-467. (Intervento presentato al convegno International Workshop on Metrology for AeroSpace (MetroAeroSpace)).

Availability:

This version is available at: 11696/61865 since: 2021-03-08T12:20:37Z

Publisher:

Published

DOI:

Terms of use:

This article is made available under terms and conditions as specified in the corresponding bibliographic description in the repository

Publisher copyright

IEEE

© 20XX IEEE. Personal use of this material is permitted. Permission from IEEE must be obtained for all other uses, in any current or future media, including reprinting/republishing this material for advertising or promotional purposes, creating new collective works, for resale or redistribution to servers or lists, or reuse of any copyrighted component of this work in other works

(Article begins on next page)

Reliable and Robust UTC(IT) Generation Based on Master and Backup Time Scales Alignment at INRiM

G. Signorile¹, V. Formichella¹, T. T. Thai¹, A. Perucca¹, E. Cantoni¹, M. Sellone¹, A. Mura¹, M. Siccardi²,
G. D. Rovera³, I. Sesia¹, F. Levi¹

¹Quantum Metrology and Nano Technologies Division, INRiM, Torino, Italy

²SKK Electronics, Cuneo, Italy

³LNE-SYRTE, Observatoire de Paris, Université PSL, CNRS, Sorbonne Université, Paris, France
g.signorile@inrim.it

Abstract— The generation of a real-time time scale with high accuracy, stability, availability and reliability is a very challenging and demanding task. Here, we describe a method applied for the generation of the Italian national time scale UTC(IT), based on the realization of two independent time scales (master and backup) which are then aligned at a high level of accuracy, so that it is possible to switch between the two at any time without discontinuities. This work is mostly focused on the alignment strategy and on the methodology adopted for monitoring and preserving the quality of the final output real-time time scale. Results of a preliminary test in real-time, based on a fully automated process, are also reported and discussed.

Keywords—time scale; robustness; reliability; switch; single point of failure.

I. INTRODUCTION

The robustness and reliability of a real-time time scale are of crucial importance in a number of applications, e.g. when such a time scale is a local realization of the Coordinated Universal Time (UTC) by a laboratory k , UTC(k), or when it is the system time of a Global Navigation Satellite System. In this work we describe a procedure for the generation of a robust and reliable real-time time scale, trying to minimize the risks connected to the presence of a single point of failure in the generation chain. Our approach is based on the realization of two independent time scales aligned to UTC, i.e. a master and a backup, so that in case of need it is possible to perform a seamless switch from the master to the backup ensuring continuity to any possible time service based on such reference signal. Although independently aligned to UTC, the two time scales may differ for a few nanoseconds since the Circular T data are available only with about 45 days latency. This is not compatible with a smooth switch in case of failure of the master time scale. Ideally the backup time scale shall be kept aligned to the master one, at a high level of accuracy. In the proposed method, the backup time scale is not just locked on the master one: the two time scales are independently steered versus UTC based on dedicated algorithms, which may also differ from one another, and on top of this, the backup time scale is aligned to the master one with an additional correction. This means that the backup time scale is almost independent of the master one, therefore it is ready to

proceed standalone and take the place of the master at any time. In order to keep the two time scales aligned, the phase offset between them is continuously measured and the collected data are used to evaluate when a phase step must be added to the backup scale. Moreover, these data can be used to monitor the performances of the two independent time scales, to assess the effectiveness of the algorithms used in the whole process, and to generate warnings or alarms in case anomalies are detected, which could eventually result in a switch if a problem of the master time scale is identified.

In section II we describe the basic setup and the realization of the two time scales. In section III we discuss the alignment procedure and how to use the collected information for monitoring purposes. Finally, in section IV, we present the first results of a preliminary test in real-time, based on a fully automated generation of the master and backup time scales and execution of the alignment procedure.

II. THE MASTER AND BACKUP TIME SCALES

The basic setup for the generation of a robust and reliable real-time time scale consists of two parallel chains, each of which includes an atomic clock (e.g. an active hydrogen maser, AHM) and a micro phase stepper device (e.g. an Auxiliary Output Generator, AOG), used to correct its frequency to steer it towards UTC.

The set-up currently used at INRiM for the generation of the UTC(IT) time scale is reported in Fig. 1. In each chain, the 5 MHz-output signal of the clock feeds the AOG, which applies the steering correction necessary to generate a time scale aligned to UTC; in such configuration, the resulting time scale is the output of the micro stepper. Note that the description of the specific steering algorithms used at INRiM is out of the scope of the present work, since they have already been discussed in [1]. The output signals of the two micro steppers are then used as inputs of a switch designed and built by SKK Electronics [2], whose output is the real-time time scale distributed to the users. The switch can seamlessly commute between the two input signals, so that continuous operation of UTC(IT) is guaranteed. The selected input signal is the master time scale, whereas the other is the backup one. Since the switch is equipped with an internal phase meter, the phase offset between the two time scales can be continuously measured, and used to compute the correction that will be

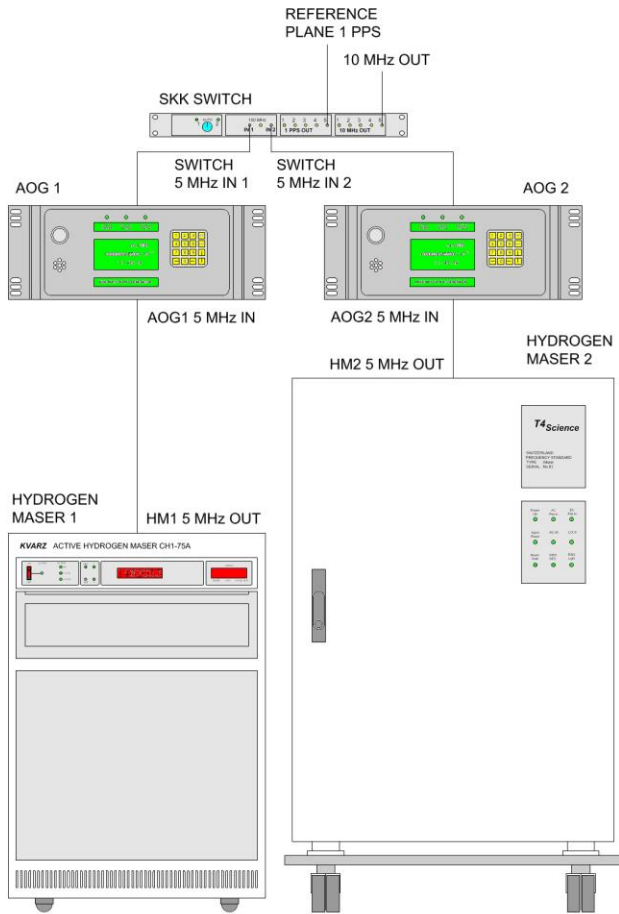

Fig. 1. INRiM set-up for the generation of the Italian national time scale UTC(IT) based on SKK switch.

applied to the backup time scale to keep it aligned to the master one within a few hundreds of picoseconds. The switch allows to easily commute from one input time scale to the other in case of failures, thus granting continuity to the final output time scale. In case a laboratory kept a backup time scale without the use of the switch, the described procedure would remain valid as the phase offset between the backup and the master time scale can be measured by making use of an external Time Interval Counter (TIC) or phase comparator (PCOMP).

III. TIME SCALES ALIGNMENT AND MONITORING

The phase offset between the two time scales is measured and recorded at INRiM on a regular basis, and it is then used to evaluate when a phase correction for the alignment of the backup time scale to the master one is required. The correction is then applied to reach a target phase offset smaller than two or three hundreds of picoseconds between the aligned time scales, so that a seamless switch can be carried out at any time without impact on the different services. The correction is directly applied as a phase step on the backup time scale, with no impact on the master one and hence on the final disseminated time scale. The phase step is obtained by a

frequency jump which is induced for a certain amount of time in order to reach the desirable phase increment.

The phase offset data, as well as the computed phase corrections, are useful information for the monitoring of the two time scales and of the whole steering and alignment process. For example, if the two independent time scales are properly generated and when the process is in its steady state, the alignment corrections are expected to have zero mean. Therefore, if the applied corrections show any kind of drift from the zero mean, this shall lead to further investigations on the clocks or on the algorithms performances.

Moreover, any anomaly affecting one of the two time scales (e.g. due to non-stationarities on the master clock, to a possible failure of a micro stepper or even to a failure of the steering algorithms) could result in a measured phase offset larger than expected. Therefore, as a further level of protection, a maximum value for the applicable correction is set, and in case such threshold is surpassed a corresponding warning/alarm is raised to notify the operator and activate corrective actions if needed. If a potentially dangerous issue is identified on the chain generating the master time scale, the switch can be then used to easily commute to the backup one, which is expected to be aligned within few hundreds of picosecond to the master one with the proposed procedure, therefore minimizing the impact on possible dissemination services and on the final users in general.

IV. AUTOMATED GENERATION OF NEW UTC(IT) TEST RESULTS

The set-up described in Fig. 1 is currently used for the generation of UTC(IT), that is the output of the switch. The alignment of the backup time scale to the master one, at the input of the switch, in this old system still in use, is performed manually, after an analysis of the phase offset measured by the phase meter inside the switch. However, our goal is to have a fully automated generation of UTC(IT), meaning both an automated generation of the independent master and backup time scales, through dedicated steering algorithms, and an automated execution of the alignment procedure, including the proposed monitoring and the generation of warnings/alarms. Therefore, in the last months, we implemented in INRiM such an automated process and tested it in real time, generating and aligning two additional time scales which are completely independent of UTC(IT) and its hot backup. The set-up used for the test is summarized in Fig. 2: two micro phase steppers are used to generate the “test master” and the “test backup” time scales, based on the same H-masers used to generate the official master and backup time scales. The phase offset between the two test time scales is then measured by an external PCOMP, since the switch is already used for the official time scales. The collected data are then used to align the “test backup” to the “test master” time scale at the input of the PCOMP (instead of at the input of the switch), and to monitor the time scales and the performances of the algorithms. For this test, the steering and alignment corrections are computed by a unique PC for both the time scales, whereas in the final configuration it is foreseen to have

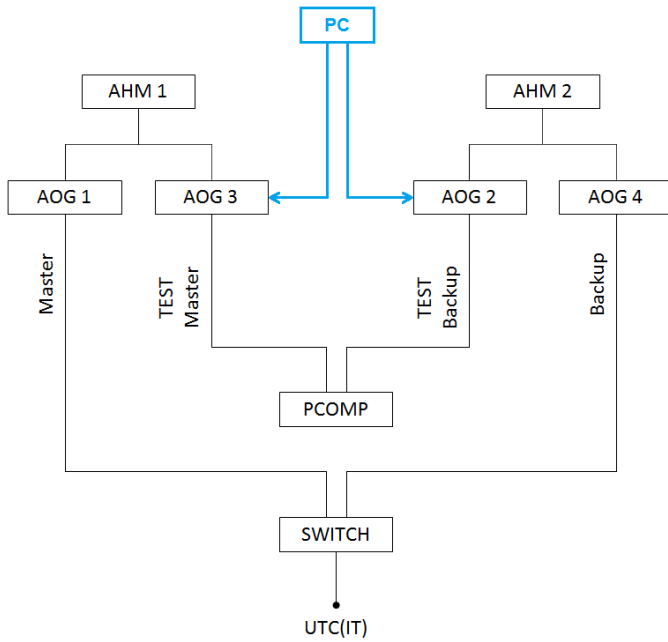

Fig. 2. INRiM set-up for the automated generation and alignment of two test time scales, using an external phase comparator instead of the SKK switch operating with UTC(IT) and its hot backup.

a dedicated PC for each time scale to ensure complete redundancy to the timescales generation system. The implemented steering algorithm is, in this test, the same for both the “test master” and the “test backup” time scale and is based on UTCr as a steering reference (see [1] for further details).

Regarding the alignment correction, in this preliminary test we adopted a simple approach in which it is computed and applied once a day, based on the last PCOMP measurement of the phase difference between the master and backup test time scales. Before to apply it, the computed correction is compared with a threshold: if the threshold is passed, the applied correction is set to zero and a warning is automatically raised and reported in the log file. In the final version of the algorithm, we will implement also a lower threshold, at the level of e.g. 200 ps: if the computed correction is lower than the threshold, then the two time scales are considered already aligned and no correction is applied.

We present here the first results of the test currently ongoing in our laboratory. We started on the 15th of May 2019 (MJD 58618), with the two test time scales aligned at the level of a few picoseconds and with an offset of about 10 ns from UTCr, which is used as steering reference. In the initialization phase, the only effect of the frequency steering correction is to compensate the frequency offset of the masers with respect to UTCr. Then, after 8 days, when the most recently published UTCr data can be used to evaluate for the first time the phase offset of the realized test time scales with respect to UTCr, an additional component is added to the steering correction. The scope of this additional component is to gradually compensate the residual phase offset of the test time scales with respect to UTCr (and hence to UTC, considering that UTCr is steered to

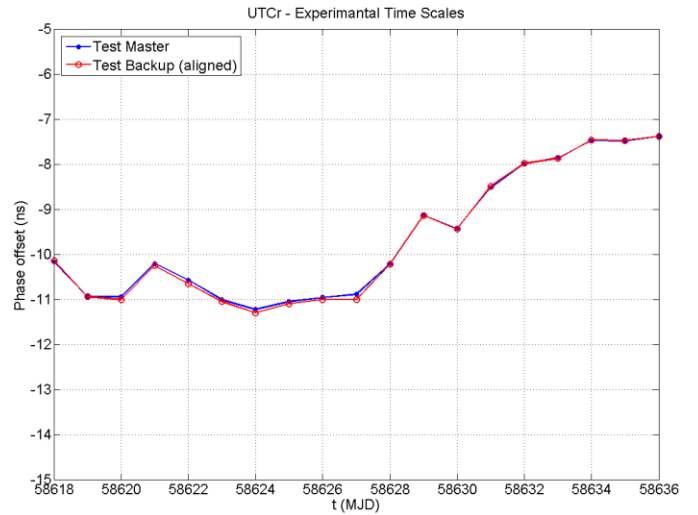

Fig. 3. Phase offset between the test time scales and UTCr during the first 19 days of test.

UTC). We chose to start with a phase offset of 10 ns in order to demonstrate the capability of the complete steering correction to recover such offset. We show in Fig. 3 the phase offset between the test time scales and UTCr for the first 19 days of test, i.e. from the beginning up to the last epoch reported in the most recently published UTCr data (MJD 58636) at the time of writing. Both the master and the aligned backup time scales are almost flat with respect to UTCr for the first 9 days, as expected. Then, when the additional component of the steering correction is applied for the first time (MJD 58626), the time scales start to converge towards UTCr; such additional component is computed in order to smoothly recover the current offset versus UTCr in about one month.

As additional comparison, in Fig. 4 we report the phase offset between the test time scales and UTC(OP) time scale [3], as measured via Two-Way Satellite Time and Frequency Transfer (TWSTFT) technique [4]. For the whole analyzed period, the two test time scales are very close to each other as a consequence of the alignment procedure, as discussed in the rest of this section.

In order to assess the performance of the alignment procedure, we plot in Fig. 5 the phase offset between the “test master” and the “test backup” time scales, as measured by the PCOMP during the first 23 days of test. The steps in the plotted data correspond to the applied alignment corrections, which are also plotted in Fig. 6. First of all, note that the phase offset between the two time scales remains well below 200 ps for the 95% over the whole period, and that the applied alignment corrections almost never exceeded 100 ps, demonstrating the effectiveness of both the steering algorithms and the alignment procedure.

In order to test also the robustness of the automated process, we intentionally introduced few hours of gaps in the PCOMP data which are used as input of the alignment algorithm, from MJD 58636 to MJD 58638.

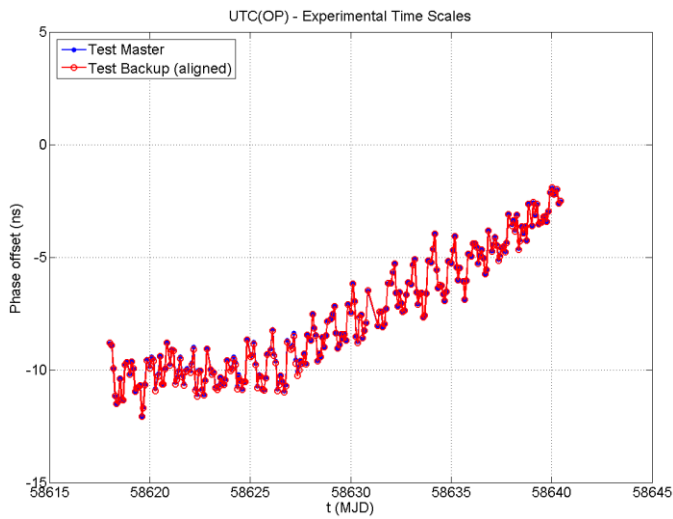

Fig. 4. Phase offset between the test time scales and UTC(OP) as measured by two way satellite time and frequency transfer, during the first three weeks of test.

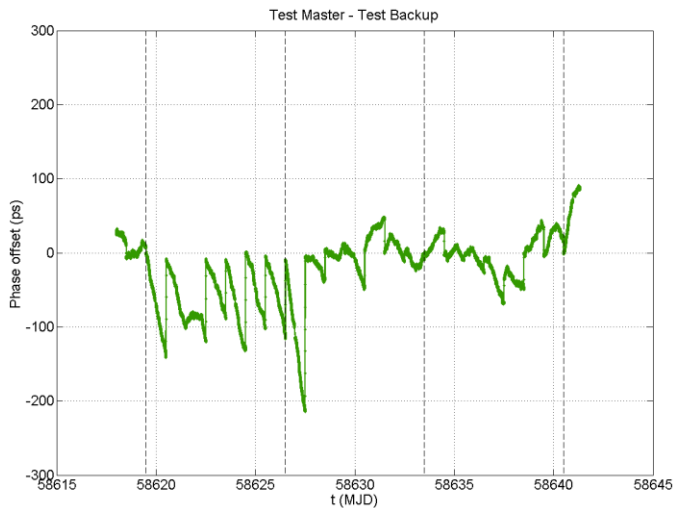

Fig. 5. Phase offset between the master and backup test time scales as measured at the PCOMP, during the three weeks of test.

The algorithm looks for the most recent phase offset measurement within the available data, and use it for the computation of an alignment correction only if it is not older than one day (configurable). However, unless the used value is very recent, the alignment correction may be different from the actual phase offset at the application epoch, and this results in a less accurate alignment (see in Fig. 5 what happens with the correction given during MJD 58637, right after one of the largest injected data gaps). Nonetheless, the backup time scales remained well aligned to the master one for the whole period, demonstrating the robustness of the automated process.

The vertical dashed lines plotted in Fig. 5 and Fig. 6, indicate the epochs at which updated UTCr data are available and have been used to compute the steering corrections. The value of the alignment corrections may be similar from day to

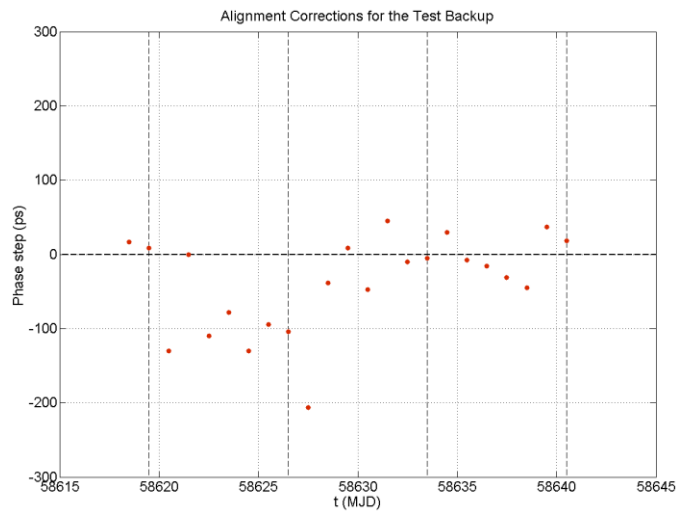

Fig. 6. Phase corrections applied to the test backup time scale to keep it aligned to the test master time scale, corresponding to the phase steps visible in Fig. 6.

day between two consecutive lines. Therefore, in order to collect meaningful statistics for the alignment corrections, e.g. to check if their mean value is consistent with zero as expected, we need to wait a longer time, i.e. a reasonable number of weeks. Nonetheless, if we compute the mean value, M , and the standard deviation, S , of the few alignment corrections plotted in Fig. 6 (only three weeks of data), we obtain $M = -39$ ps and $S = 65$ ps, which are promising results.

The results presented above can be considered as a preliminary successful validation of the automated process for generating and aligning two time scales.

V. CONCLUSIONS

We have demonstrated a method for the generation of a robust and reliable real-time hardware time scale, based on two independent time scales automatically aligned by a simple and effective algorithm.

The totally independent backup time scale is steered versus UTC and kept aligned to the master time scale (which is also independently steered towards UTC) within few hundreds of picoseconds, thanks to an additional phase step correction applied to the backup time scale.

In the final configuration the automatic alignment procedure will be realized at INRiM by means of a dedicated switch, currently in use at INRiM to commute between the official master and the backup time scale.

In the current set-up the switch is emulated by a PCOMP that measure the time difference between the master test and backup test time scales. Such offset is not only used to estimate the additional correction to keep aligned the backup time scale to the master one, but also for monitoring purposes, in order to quickly identify possible anomalies and activate corrective actions to minimize any impact on the final time scale.

The results of the preliminary test are well promising, showing that the two timescales can be easily kept aligned at the level of a few hundreds of picoseconds with small daily corrections.

The proposed method does not depend on the specific atomic clocks, algorithms or electronic devices included in the set-up of the master and backup time scale generation chains, and it is therefore of general applicability, especially in those applications where the availability, robustness and reliability of the final real-time time scale are crucial.

REFERENCES

- [1] L. Galleani, G. Signorile, V. Formichella, I. Sesia, "Generating a Real-Time Time Scale With an Ensemble Clock and a Primary Frequency Standard", to be published in Proc. of the 2019 Joint Conference of the IEEE International Frequency Control Symposium & European Frequency and Time Forum, Orlando, 2019.
- [2] M. Sellone, R. Costa, A. Mura, G. Cerretto, F. Levi and M. Siccardi, "Improvements on the UTC(IT) timescale at INRIM", in Proc. of the 2018 European Frequency and Time Forum, Turin, 2018, pp. 188-191.
- [3] G. D. Rovera, S. Bize, B. Chupin, J. Guéna, Ph. Laurent, P. Rosenbusch, P. Urich and M. Abgrall, "UTC(OP) based on LNE-SYRTE atomic fountain primary frequency standards", *Metrologia* 53 S81, 2016.
- [4] D. Kirchner, "Two-way Time Transfer Via Communication Satellites", in Proc. of the IEEE, Vol. 79, no. 7, July 1991.