



## ISTITUTO NAZIONALE DI RICERCA METROLOGICA Repository Istituzionale

Automated setup to accurately calibrate electrical dc voltage generators

This is the author's accepted version of the contribution published as:

*Original*

Automated setup to accurately calibrate electrical dc voltage generators / Galliana, Flavio; Capra, Pier Paolo; Cerri, Roberto; Lanzillotti, Marco. - In: MEASUREMENT. - ISSN 0263-2241. - 123:(2018), pp. 129-134. [10.1016/j.measurement.2018.03.062]

*Availability:*

This version is available at: 11696/57805 since: 2021-03-05T18:53:33Z

*Publisher:*

Elsevier

*Published*

DOI:10.1016/j.measurement.2018.03.062

*Terms of use:*

This article is made available under terms and conditions as specified in the corresponding bibliographic description in the repository

*Publisher copyright*

(Article begins on next page)

# AUTOMATED SETUP TO ACCURATELY CALIBRATE ELECTRICAL DC VOLTAGE GENERATORS

Flavio Galliana, Pier Paolo Capra, Roberto Cerri and Marco Lanzillotti

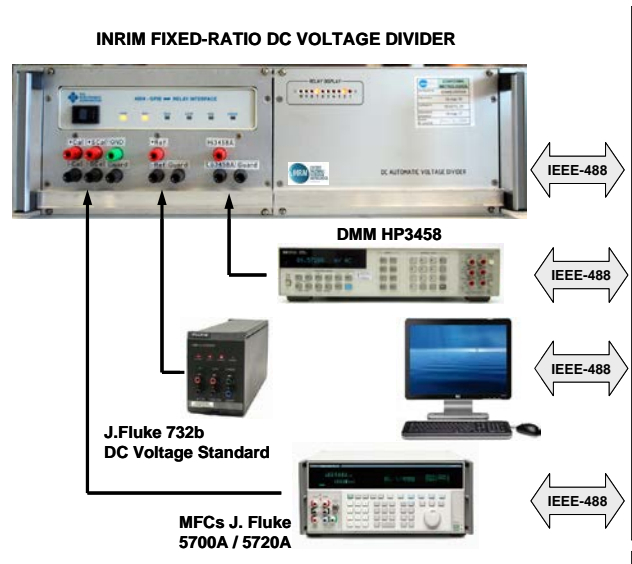
**Abstract**—At National Institute of Metrological Research (INRIM), an automated setup to calibrate dc voltage generators, mainly top-level calibrators, from 1 mV to 1 kV has been developed. The heart of the setup is an INRIM-built automated precision fixed ratios dc voltage divider. It can be interconnected to a DMM characterized in linearity, to a dc voltage standard and to a dc voltage generator under calibration to manage automatically the calibration process. Novelty of the system is the employment of the divider being such an instrument not commercially available. Main results are the improvement of the reliability and the increasing of the accuracy of the calibration process saving a lot of time. In addition, it is possible to avoid several standards (still manually operating) carrying out the whole process without changing the setup configuration and without the presence of operators. The expanded uncertainties of the system span from  $6.0 \times 10^{-7}$  to  $1.3 \times 10^{-4}$  improving the previous capabilities of the INRIM laboratory for calibration of multifunction instruments. The setup concept can be transferred to secondary high-level electrical laboratories to improve and expedite their calibrations.

**Index Terms**—Dc voltage, generator, calibration, multifunction calibrator, dc voltage standard, multi-meter, dc voltage divider, measurement uncertainties.

## 1. INTRODUCTION

In low frequency electrical measurements, programmable multifunction generating and measuring instruments as calibrators (MFCs) and multi-meters (DMMs) [1] are widespread in primary,

secondary and industrial calibration laboratories. They combine the five main electrical functions (dc and ac voltage and current and dc resistance) operating in very large fields. To achieve their best performance, these instruments require periodic and complex calibrations involving several instruments and standards. Traditionally, in dc voltage, manually operating dividers have been used [2, 3]. With these instruments, the calibration of generators in dc voltage requires a lot of time increasing the costs. To overcome these problems, at the laboratory for calibration of programmable multifunction instruments (INRIM-Lab) of the National Institute of Metrological Research (INRIM), an automated setup to calibrate dc voltage generators has been developed. This system allows the interconnection of a generator, of a DMM and of a dc voltage standard through an INRIM-built precision automated dc voltage fixed ratios divider. An advantage of this setup is to carry out the whole calibration process avoiding any manipulation or change of the circuit configuration. The calibration process consists, in a first step, in the calibration of the DMM at 10 V vs. the dc voltage standard, successively the quick calibration 10:1 and 100:10 divider ratios and finally the calibration of the generator in the 1 mV÷1 kV range, using the divider and the DMM as standards. Nevertheless, the three steps are independent of each other and can therefore be executed in different times. The system (block scheme of Fig. 1) has been developed specifically involving the DMM HP3458A [4] for its excellent linearity on the 10 V range and the J. Fluke 5700A calibrator as generator [5]. Other generators or calibrators can also be calibrated customizing the calibration program. The full process is complete in 10–12 hours (according to the chosen delays and repetitions) while in the past similar calibration required about a week with the presence of the operators introducing undesired noises.



**Fig.1.** Block scheme of the INRIM setup to calibrate dc voltage generators.

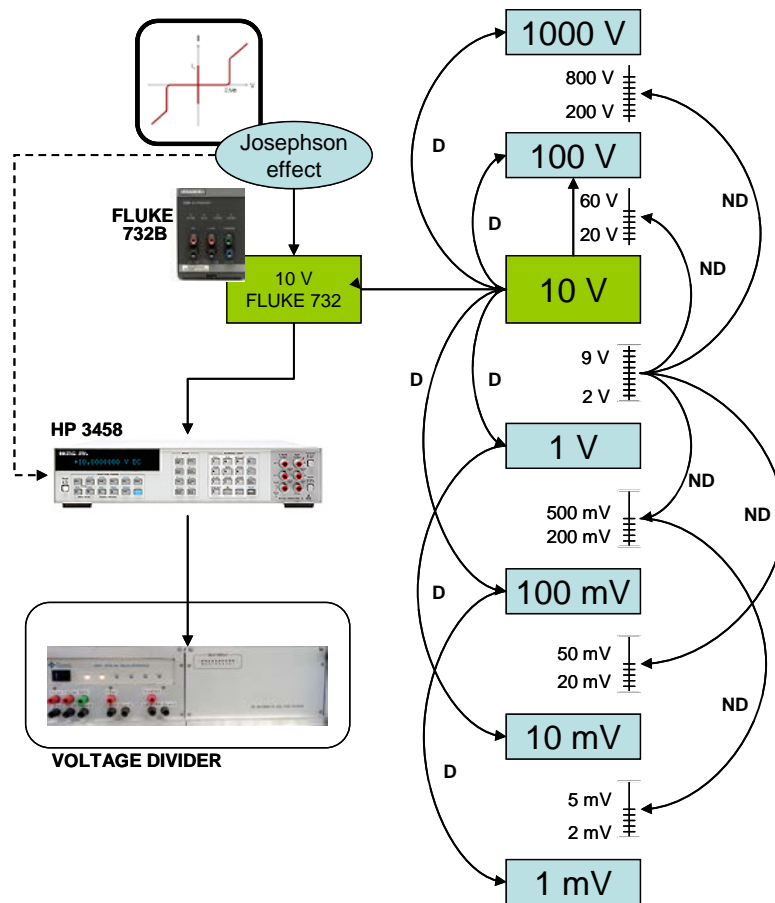
## 2. THE INRIM FIXED-RATIOS DC VOLTAGE DIVIDER

The INRIM-built automated dc voltage resistive divider (external view in Fig. 1) allows the 10:1, 100:10 and 100:1 division ratios and can be connected with a dc voltage generator, a DMM and a dc voltage standard. Taking advantage of the DMM excellent linearity on the 10 V range, the divider ratios 10:1 and 100:10 can be quickly calibrated by means of the measurement setup of Fig. 3 (excluding the 10V standard). **Full details about the divider, about its calibration procedure also validated in comparison with another method and about its calibration uncertainties are reported in [6].**

## 3. THE AUTOMATIC CALIBRATION SETUP OF DC VOLTAGE GENERATORS

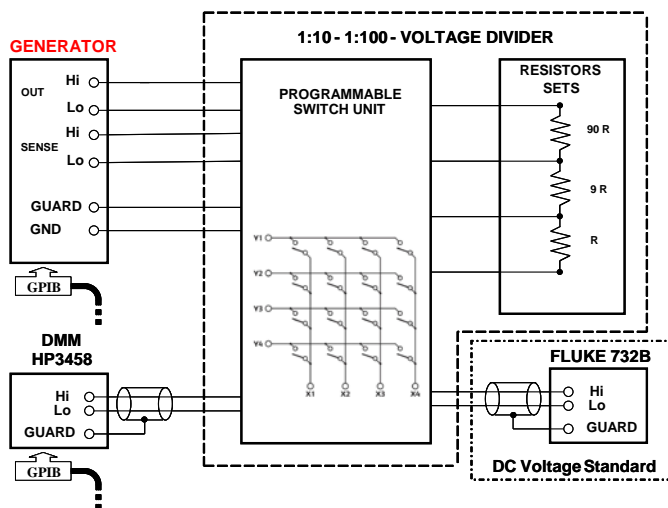
The calibration process of dc voltage generators consists in three steps. The first is the calibration of the DMM at 10 V vs. a 10 V standard (calibrated in turn vs. the Josephson effect) connecting directly it to the DMM. The mean value of positive and negative readings corrected by the offsets and by the deviation from the 10 V reference value, is evaluated. The linearity of the 10 V range of the DMM is periodically verified vs. the Josephson effect as suggested in [7, 8]. The verification of the DMM linearity and the fast calibration process allow to take into account the uncertainties of the linearity characterization of the DMM and the DMM transfer Accuracy/linearity specifications for

the other ranges, being both much smaller than the DMM Accuracy specifications. The second step is the quick calibration of the 10:1 and 100:10 divider ratios and the calculation of the 100:1 ratio value [6]. Final step (described in next paragraph) is the calibration of generators from 1 mV to 1 kV, using the divider and the DMM as standards. This step is made according to the ranges of the generators under calibration as shown in Fig. 2.

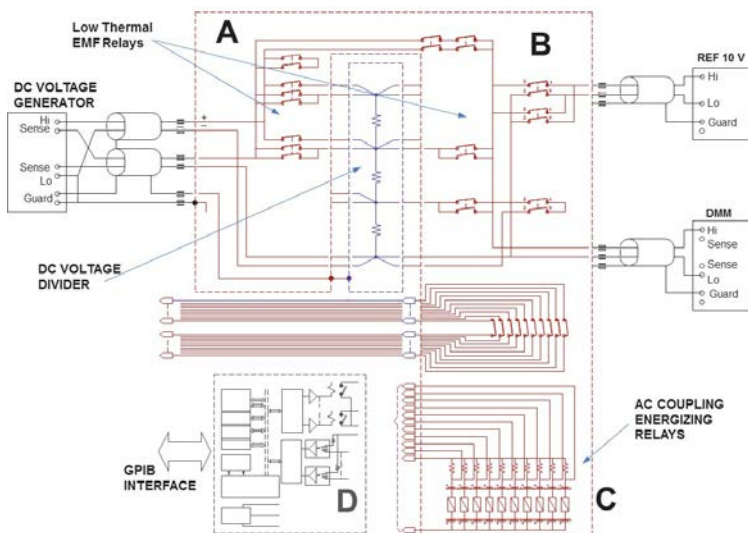


**Fig. 2.** Diagram of the calibration process. The value of the 10V is the key point of the traceability from a high precision Zener dc voltage standard calibrated vs. the Josephson effect. The calibration steps are symbolized with D for decade values and with ND for not-decade values.

Fig. 3, 4 and 5 shows the block scheme, the electrical scheme and a photo of the measurement setup respectively.



**Fig. 3.** Setup to calibrate dc voltage generators: the divider can be connected to the generator, to the DMM and to the dc voltage standard. The generator is set on internal guard (whenever available), while the generator ground terminal is connected to the low and guard terminals (connected together) of the divider. The DMM is set to “guard open” and its guard terminal is connected to the divider guard terminal.



**Fig. 4.** Simplified scheme of the divider connected to the measurement setup. The whole calibration process is allowed by means of a relays network witch sets the divider ratio, configure the device under measurement and include or exclude the voltage reference. In particular, the relay sets A and B invert both the voltage of the generator and of the 10 V standard. The last relays group controls the resistors sets of the divider. C - the relays coils are pulse-controlled through two electrolytic capacitors to decouple the relays from the control circuit. D - commercially available GPIB to digital I/O interface.



**Fig. 5.** Photo of the measurement setup to calibrate a top-level calibrator. a) INRIM fixed-ratios divider, b) voltage standard, c) calibrator, d) DMM.

#### 4. MAIN CALIBRATION POINTS OF GENERATORS

At the INRIM-Lab, the calibration points for the generators are chosen according to [9]. This guide suggests that the calibration points should be the full scale values and the values required for the adjustment of multifunction instruments. In the following, the steps of the calibration of generators in some measurement values and ranges, are discussed. The calibration of a generator is always made connecting it to the DMM through the divider allowing the automation of the process. Zero check is always made at every change of the range of a generator under calibration and the zero mean value is algebraically added to the successive measurements. Particular care for this operation is paid for the lowest values. Usual calibration points and ranges for a generator [5] are:

- Positive and negative values 100 mV, 1 V and 10 V, starting from 10 V with a step-down process, 100 V and 1 kV values with a step-up process;
- Positive and negative values from 1mV to 9 V with a step-down process;
- Positive and negative values from 20 V to 800 V with a step-up process.

For each measurement point, the average of the positive and negative mean values from the generator under calibration read by the DMM are considered and stored.

#### **4.1 Calibration at 10 V, 1 V, 100 mV and 10 mV**

The calibration of a generator, at 10V is made connecting it to the DMM through the divider set in 1:1 ratio and reading with the DMM. The calibration at 1 V is made in two steps: In the first, the generator supplies the just calibrated 10 V value to the DMM operating on the 1V range through the divider in 10:1 ratio. The output value from the divider read by the DMM allows its calibration at 1 V. In the second step, without removing the connections and with the divider in 1:1 ratio, setting the generator to 1 V, the DMM measures this value calibrating the generator at 1 V. The calibration at 100 mV is like that of the 1 V, setting only the divider in 100:1 ratio in the first step. The calibration at 10 mV is like that of the 100 mV, starting from the just calibrated 1 V. Same steps are followed for negative values.

#### **4.2 Calibration at 100 V and 1000 V**

The calibrations of a generator at 100 V and 1000 V are made in single steps with the generator supplying alternatively these voltages and setting the divider ratio in 10:1 or 100:1 respectively and reading with the DMM on the 10 V range.

#### **4.3 Calibration in other points**

##### *4.3.1 Calibration from 2 V to 9 V*

The values from 2 to 9 V lie between two ranges of the generator [5] (2.2V and 11 V) that are automatically selected by the control program written in Visual Basic 2008. The calibration is made setting the divider in 1:1 ratio. The voltages from the generator are directly read by the DMM on the 10 V range, taking advantage of the verification of its linearity.

##### *4.3.2 Calibration from 200 mV to 500 mV*

These values lie between the 220 mV and 2.2 V ranges of the generator. The calibration is made in two steps. In the first, the divider is set in 10:1 ratio and the generator supplies the just calibrated 2 V to 5 V values. The output values from the divider read by the DMM allow its



calibration from 200 mV to 500 mV. In the second step, setting the divider in 1:1 ratio, the DMM reads the values from the generator calibrating it in the specified range.

#### 4.3.3 Calibration from 10 mV to 50 mV

The procedure utilizes the just calibrated 1 V to 5 V values of the generator (changing the range from 2.2 V to 22 V). The calibration steps are the same as from 200 mV to 500 mV, with the divider in 100:1 ratio in the first step.

#### 4.3.4 Calibration from 1 mV to 5 mV

This procedure is like that of the previous sub-paragraph with the only difference that the generator utilizes the just calibrated 100 mV to 500 mV values of the generator (changing the range from 220 mV to 2.2 V).

#### 4.3.5 Calibration from 20 V to 80 V and from 200 V to 800 V

The calibration from 20 V to 80 V is made setting the divider in 10:1 ratio and reading the voltages from the generator directly with the DMM on the 10 V range. The calibration from 200 V to 800 V is the same, setting the divider in 100:1 ratio.

## 5. CALIBRATION UNCERTAINTIES

In Table 1 relative standard uncertainties budget of the calibration of the DMM at 10 V vs. the dc voltage standard is given.

**Table 1**

Relative standard uncertainty budget of the calibration of the DMM at 10 V.

Component	type	$1 \sigma$ ( $\times 10^{-7}$ )
Dc voltage standard:		
Calibration	Rectangular B	2.9
Temp. effect	Rectangular B	0.1
Drift	Rectangular B	1.0
Emf <sup>a</sup>	Rectangular B	0.1
Noise at the output terminals	Rectangular B	0.3
DMM noise	Normal A	0.3
<b>RSS</b>		<b>3.1</b>

<sup>a</sup> These emfs are due to the contacts between the gold plated sockets and the brass connectors

## 5.1 Calibration uncertainties of generators

In Tables from 2 to 6 the relative standard uncertainties budgets of the calibration of a generator [5] at some voltages, are given.

**Table 2**

Relative standard uncertainties budget of the calibration of a generator at 10 V, 100 V and 1000 V.

Component	type	$1 \sigma (\times 10^{-7})$
Divider 1:1 <sup>b</sup>	Rectangular B	0.02
DMM noise	Normal A	0.3
DMM calibration at 10 V	Normal B	3.1
DMM drift at 10 V <sup>c</sup>	Rectangular B	0.1
Linearity error at 10 V	Rectangular B	negl.
<b>RSS → Generator at 10 V</b>		<b>3.1</b>
Divider 10:1	Rectangular B	2.7
DMM noise	Normal A	0.3
DMM calibration at 10 V	Normal B	3.1
DMM cal. drift at 10 V <sup>c</sup>	Rectangular B	0.1
Linearity error 10 V	Rectangular B	negl.
<b>RSS → Generator at 100 V</b>		<b>4.1</b>
Divider 100:1	Rectangular B	3.8
DMM noise	Normal A	0.3
DMM calibration at 10 V	Normal B	3.1
DMM cal. drift at 10 V <sup>c</sup>	Rectangular B	0.1
Linearity error 10 V	Rectangular B	negl.
<b>RSS → Generator at 1000 V</b>		<b>4.9</b>

**Table 3.**

Relative standard uncertainties budget of the calibration of a generator at 1V, 100 mV and 10 mV.

Component	type	$1 \sigma (\times 10^{-7})$
Generator calibrated at 10 V	Rectangular B	3.1
Divider 10:1	Rectangular B	2.7
DMM noise	Normal A	0.3
Emf	Rectangular B	0.3
Temp. eff. on generator	Rectangular B	0.2
<b>RSS → DMM at 1 V</b>		<b>4.1</b>
Divider 1:1	Rectangular B	0.02
DMM noise	Normal A	0.4
Linearity error 1 V <sup>d</sup>	Rectangular B	1.9
Emf	Rectangular B	0.3
<b>RSS → Generator at 1 V</b>		<b>4.6</b>
Generator calibrated at 10 V	Rectangular B	3.1
Divider 100:1	Rectangular B	3.8
DMM noise	Normal A	0.5
Emf	Rectangular B	0.6
Temp. eff. on generator	Rectangular B	0.2
<b>RSS → DMM at 100 mV</b>		<b>5.0</b>
Divider 1:1	Rectangular B	0.02
DMM noise	Normal A	3.0
Transfer. accuracy 100 mV	Rectangular B	5.8
Emf	Rectangular B	0.6
<b>RSS → Generator at 100 mV</b>		<b>8.2</b>
Generator calibrated at 1 V	Rectangular B	4.6
Divider 100:1	Rectangular B	3.8

<sup>b</sup> To estimate this value, the effects of the emfs of the relays were considered.

<sup>c</sup> This value takes into account the DMM short-time drift from its calibration at 10 V.

<sup>d</sup> This value is obtained from the calibration certificate regarding the verification of the DMM linearity on the 10 V range.

DMM noise	Normal A	40
Emf	Rectangular B	17
Temp. eff. on generator	Rectangular B	0.9
<b>RSS → DMM at 10 mV</b>		<b>44</b>
Divider 1:1	Rectangular B	0.02
DMM noise	Normal A	40
Transfer. accuracy 10 mV	Rectangular B	32
Emf	Rectangular B	17
<b>RSS → Generator at 10 mV</b>		<b>70</b>

**Table 4**

Relative standard uncertainties budget of the calibration of a generator at 5V and at 0.5 V.

Component	type	$1 \sigma$ ( $\times 10^{-7}$ )
DMM calibration at 10 V	Normal B	3.1
DMM cal. drift at 10 V <sup>c</sup>	Normal A	0.1
Divider 1:1	Rectangular B	0.02
DMM noise	Normal A	0.5
Linearity error <sup>4</sup>	Rectangular B	0.5
<b>RSS → Generator at 5 V</b>		<b>3.3</b>
Divider 10:1	Rectangular B	2.7
DMM noise	Normal A	1.0
Emf	Rectangular B	0.6
Temp. eff. on generator	Rectangular B	0.9
<b>RSS → DMM at 0.5 V</b>		<b>4.5</b>
divider 1:1	Rectangular B	0.02
DMM noise	Normal A	1.0
Transfer. accuracy 0.5 V	Rectangular B	2.9
Emf	Rectangular B	0.6
<b>RSS → Generator at 0.5 V</b>		<b>5.5</b>

**Table 5**

Relative standard uncertainties budget of the calibration of a generator at 50mV and at 5 mV.

Component	type	$1 \sigma$ ( $\times 10^{-7}$ )
Generator calibrated at 5 V	Normal B	3.3
Divider 100:1	Rectangular B	3.8
DMM noise	Normal A	10
Emf	Rectangular B	12
Temp. eff. on generator	Rectangular B	0.9
<b>RSS → DMM at 50 mV</b>		<b>16</b>
Divider 1:1	Rectangular B	0.02
DMM noise	Normal A	10
Transfer. accuracy 50 mV	Rectangular B	5.8
Emf	Rectangular B	12
<b>RSS → Generator at 50 mV</b>		<b>23</b>
Generator calibrated at 0.5 V	Normal B	5.5
Divider 100:1	Rectangular B	3.8
DMM noise	Normal A	80
Emf	Rectangular B	17
Temp. eff. on generator	Rectangular B	1.3
<b>RSS → DMM at 5 mV</b>		<b>82</b>
Divider 1:1	Rectangular B	0.02
DMM noise	Normal A	80
Emf	Rectangular B	17
Transfer. accuracy 5 mV	Rectangular B	61
<b>RSS → Generator at 5 mV</b>		<b>131</b>

**Table 6**

Relative standard uncertainties budget of the calibration of a generator at 50V and at 500 V.

Component	type	$1 \sigma$ ( $\times 10^{-7}$ )
Divider 10:1	Rectangular B	2.7
DMM noise	Normal A	0.6
DMM calibration 10 V	Normal B	3.1
DMM calibration drift <sup>c</sup>	Rectangular B	0.1
Emf	Rectangular B	1.2
Linearity error <sup>d</sup>	Rectangular B	0.5
<b>RSS → Generator at 50 V</b>		<b>4.3</b>
Divider 100:1	Rectangular B	3.8
DMM noise	Normal A	0.4
DMM calibration 10 V	Normal B	3.1
DMM calibration drift <sup>c</sup>	Rectangular B	0.1
Emf	Rectangular B	0.2
Linearity error <sup>d</sup>	Rectangular B	0.5
<b>RSS → Generator at 500 V</b>		<b>4.9</b>

In Table 7 the relative expanded uncertainties (i.e. the best measurement capabilities) of the INRIM-Lab for the calibration of generators from 1 mV to 1 kV before and after the introduction of this setup, are listed.

**Table 7**

Relative expanded uncertainties of the calibration of generators from 1 mV to 1 kV. The table is referred to the calibration of a J. FLUKE 5700A calibrator. The uncertainties are grouped in measurement ranges according to the publication criteria of the CIPM-MRA database<sup>e</sup>.

Dc voltage ranges	Previous capabilities ( $\mu\text{V}/\text{V}$ ) <sup>f</sup>	New capabilities ( $\mu\text{V}/\text{V}$ ) <sup>f</sup>
$\pm 1 \text{ mV}$	192	127
$\pm 1 \text{ mV to } \pm 3 \text{ mV}$	65	47
$\pm 3 \text{ mV to } \pm 5 \text{ mV}$	42	26
$\pm 5 \text{ mV to } \pm 10 \text{ mV}$	23	13.9
$\pm 10 \text{ mV to } \pm 30 \text{ mV}$	11	5.1
$\pm 30 \text{ mV to } \pm 50 \text{ mV}$	8.5	4.8
$\pm 50 \text{ mV to } \pm 200 \text{ mV}$	2.2	1.5
$\pm 200 \text{ mV to } \pm 300 \text{ mV}$	1.9	1.3
$\pm 300 \text{ mV to } \pm 500 \text{ mV}$	1.7	1.1
$\pm 500 \text{ mV to } \pm 1 \text{ V}$	0.9	0.9
$\pm 1 \text{ V to } \pm 2 \text{ V}$	1.2	0.7
$\pm 2 \text{ V to } \pm 3 \text{ V}$	0.9	0.7
$\pm 3 \text{ V to } \pm 4 \text{ V}$	0.8	0.7
$\pm 4 \text{ V to } \pm 5 \text{ V}$	0.8	0.7
$\pm 5 \text{ V to } \pm 6 \text{ V}$	0.7	0.7

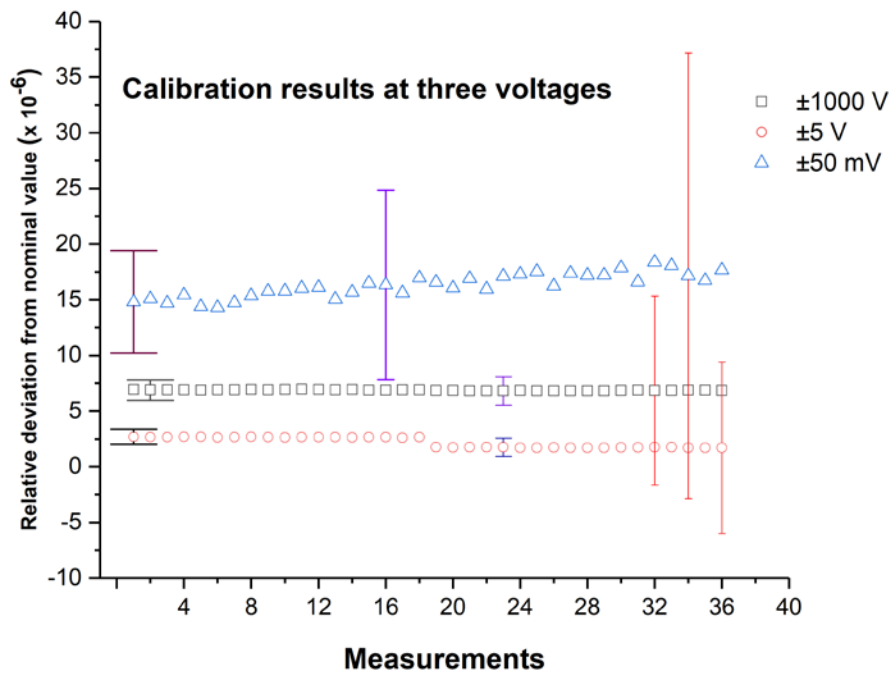
<sup>e</sup> The CIPM Mutual Recognition Arrangement (CIPM MRA) is the framework through which National Metrology Institutes demonstrate the international equivalence of their measurement standards and the calibration and measurement certificates they issue. The outcomes of the Arrangement are the internationally recognized (peer-reviewed and approved) [Calibration and Measurement Capabilities \(CMCs\)](#) of the participating institutes.

<sup>f</sup> For some measurement values in consecutive ranges (as the last value of a range and the first of the following range, excluding the 1 mV) the better uncertainty value should be considered.

$\pm 6 \text{ V to } \pm 7 \text{ V}$	0.7	0.7
$\pm 7 \text{ V to } \pm 8 \text{ V}$	0.7	0.7
$\pm 8 \text{ V to } \pm 9 \text{ V}$	0.7	0.6
$\pm 9 \text{ V to } \pm 10 \text{ V}$	0.6	0.6
$10 \text{ V to } \pm 12 \text{ V}$	0.8	0.6
$\pm 12 \text{ V to } \pm 20 \text{ V}$	0.9	0.9
$\pm 20 \text{ V to } \pm 30 \text{ V}$	0.9	0.9
$\pm 30 \text{ V to } \pm 40 \text{ V}$	1.1	0.9
$\pm 40 \text{ V to } \pm 50 \text{ V}$	1.2	0.9
$\pm 50 \text{ V to } \pm 60 \text{ V}$	1.4	0.9
$\pm 60 \text{ V to } \pm 80 \text{ V}$	1.7	0.9
$\pm 80 \text{ V to } \pm 100 \text{ V}$	0.8	0.8
$\pm 100 \text{ V to } \pm 200 \text{ V}$	1.6	1.0
$\pm 200 \text{ V to } \pm 300 \text{ V}$	1.4	1.0
$\pm 300 \text{ V to } \pm 400 \text{ V}$	1.4	1.0
$\pm 400 \text{ V to } \pm 500 \text{ V}$	1.4	1.0
$\pm 500 \text{ V to } \pm 600 \text{ V}$	1.3	1.0
$\pm 600 \text{ V to } \pm 800 \text{ V}$	1.3	1.0
$\pm 800 \text{ V to } \pm 1000 \text{ V}$	1.3	1.0

## 6. MEASUREMENT RESULTS

Fig. 6 shows the positive and negative dc voltage readings of the DMM at the output of the fixed-ratios divider calibrating a generator. Calibration values are obtained averaging the DMM measurements, acquired after a suitable delay to stabilize the readings.



**Fig. 6.** Calibration results at three dc voltage values of a calibrator [5]. The bars with small caps indicate the one-year accuracy specifications of the calibrator, those with medium caps indicate the old system uncertainties while those with large caps indicate the new setup uncertainties.

## CONCLUSIONS

From Table 7 it is possible to see that the relative uncertainties (best measurement capabilities) of the INRIM-Lab for the calibration of dc voltage generators from 1 mV to 1 kV, after the introduction of the new setup, improved. Other achievements are the time saving and the measurement reliability as the calibration process can run without the presence of operators. The dc voltage results of a measurement comparison between the INRIM-Lab and a high level secondary electrical laboratory made with the new system [10] were re-calculated with the new uncertainties<sup>g</sup> maintaining the agreement with this laboratory. This exercise represents a first validation of the setup. In future, further comparisons will be made to check the reliability of the system. For example, the calibration of the INRIM-built selectable-value **transportable high dc voltage standard** (THVS) [11] with this setup will be compared with the calibration system of the THVS itself. Other aims are the updating the INRIM capabilities in the CIPM MRA database and the transfer of the setup concept to secondary calibration laboratories or to other National Metrology Institutes.

## Acknowledgment

The authors wish to thank Cristina Cassiogo that wrote the software to manage the calibration process and for her support in the elaboration of the paper.

## References

- [1] C. Cassiogo, G. La Paglia, U. Pogliano, “Stability evaluation of high-precision multifunction instruments for traceability transfer,” IEEE Trans. Instrum. Meas. Vol. 50, no. 6 pp. 1206–1210, Dec. 2000.
- [2] Fluke Corporation, 752 A Reference Divider Instruction Manual, Revision 1, 1984.
- [3] Fluke Corporation, 720 A Kelvin Varley Voltage Divider Instruction Manual, Revision 2, 1974.

<sup>g</sup> For this comparison the old uncertainties, as still published in the BIPM-MRA CMC database, were declared because the comparison results were reported also in an INRIM legal document (an ILC report) to be presented by the laboratory itself to the accreditation body for the accreditation maintenance.

- [4] Agilent Technologies, 3458A Multimeter - User's Guide, Revision: B.01, March 2001.
- [5] Fluke Corporation, 5700A/5720A Series II Multi-Function Calibrator Service Manual, Rev. 1, 3/02, June 1996.
- [6] F.Galliana, P.P. Capra R. Cerri, M. Lanzillotti,, "Automated precision DC voltage fixed ratios divider", *Measurement Vol. 122*, pp.291–296, March 2018.
- [7] A. Sosso and R. Cerri, "Calibration of multimeters as Voltage Ratio Standards," in *Prec. Elec. Conf. CPEM 2000, Sydney (AU), 2000*, pp. 375–376.
- [8] J. I. Giem, "Sub-ppm linearity testing of a DMM using a Josephson junction array," *IEEE Trans. Instrum. Meas.*, Vol. 40 no. 2, pp. 329–332, 1991.
- [9] EURAMET cg-15, Guidelines on the Calibration of Digital Multimeters, version 3.0, 02/2015, previously EA-10/15.
- [10] F. Galliana and M. Lanzillotti, "Accurate comparison between INRIM and a secondary calibration laboratory using a top-class multifunction electrical calibrator," *Measurement Vol. 103*, pp. 353–360, 2017.
- [11] F. Galliana, R. Cerri and M. Roncaglione Tet, "High performance selectable-value transportable high dc voltage standard," *Measurement Vol. 102*, pp. 131–137, 2017.