



## ISTITUTO NAZIONALE DI RICERCA METROLOGICA Repository Istituzionale

High performance selectable-value transportable high DC voltage standard

This is the author's accepted version of the contribution published as:

*Original*

High performance selectable-value transportable high DC voltage standard / Galliana, Flavio; Cerri, Roberto; RONCAGLIONE TET, Luca. - In: MEASUREMENT. - ISSN 0263-2241. - 102:(2017), pp. 131-137. [10.1016/j.measurement.2017.02.002]

*Availability:*

This version is available at: 11696/54265 since: 2021-03-05T18:56:02Z

*Publisher:*

Elsevier

*Published*

DOI:10.1016/j.measurement.2017.02.002

*Terms of use:*

This article is made available under terms and conditions as specified in the corresponding bibliographic description in the repository

*Publisher copyright*

(Article begins on next page)

# HIGH PERFORMANCE SELECTABLE-VALUE TRANSPORTABLE HIGH DC VOLTAGE STANDARD

Flavio Galliana<sup>1</sup>, Roberto Cerri<sup>2</sup>, Luca Roncaglione Tet<sup>3</sup>

<sup>1,2,3</sup>) *National Institute of Metrological Research, strada delle Cacce 91, 10135 TURIN – Italy*

<sup>1</sup>Phone + 39 011 3919336, fax + 39 011 346384 f.galliana@inrim.it

<sup>2</sup> Phone + 39 011 3919426, fax + 39 011 346384 r.cerri@inrim.it

<sup>3</sup> Phone + 39 011 3919421, fax + 39 011 346384 l.roncaglione@inrim.it

## ABSTRACT

At National Institute of Metrological Research (INRIM), a selectable-value transportable high dc voltage standard (THVS) operating in the range from 10 V to 100 V in steps of 10 V, was developed. This standard was built to cover the lack of high level dc voltage standards at values higher than 10 V to employ mainly as transportable standard for inter-laboratory comparisons (ILCs) or eventually as laboratory (local) high level dc voltage standard. An electronic technique was used to improve the THVS accuracy of the high values. The THVS shows lower noise, better short- term stability and accuracy than top level dc voltage and multifunction calibrators (MFCs) and satisfactory suitability to be transported. The project is extensible to 1000 V.

**Keywords:** Dc voltage standard, inter-laboratory comparison, measurement stability, measurement uncertainty, transport effect, travelling standard.

## 1. Introduction

Nowadays, the dc voltage standard is reproduced from the standard of time by means of the Josephson effect [1] while its maintenance is granted by Zener-diode-based dc voltage standards that are periodically calibrated by means of the Josephson effect [1–3]. These devices are excellent travelling standards due to their ability to reject physical shocks and temperature changes and their possibility to operate in battery mode. For this reason they are involved in interlaboratory comparisons (ILCs) at international and national level [4–7]. They are also used for the “artifact calibration” by means of which some high accuracy multifunction instruments can be calibrated and

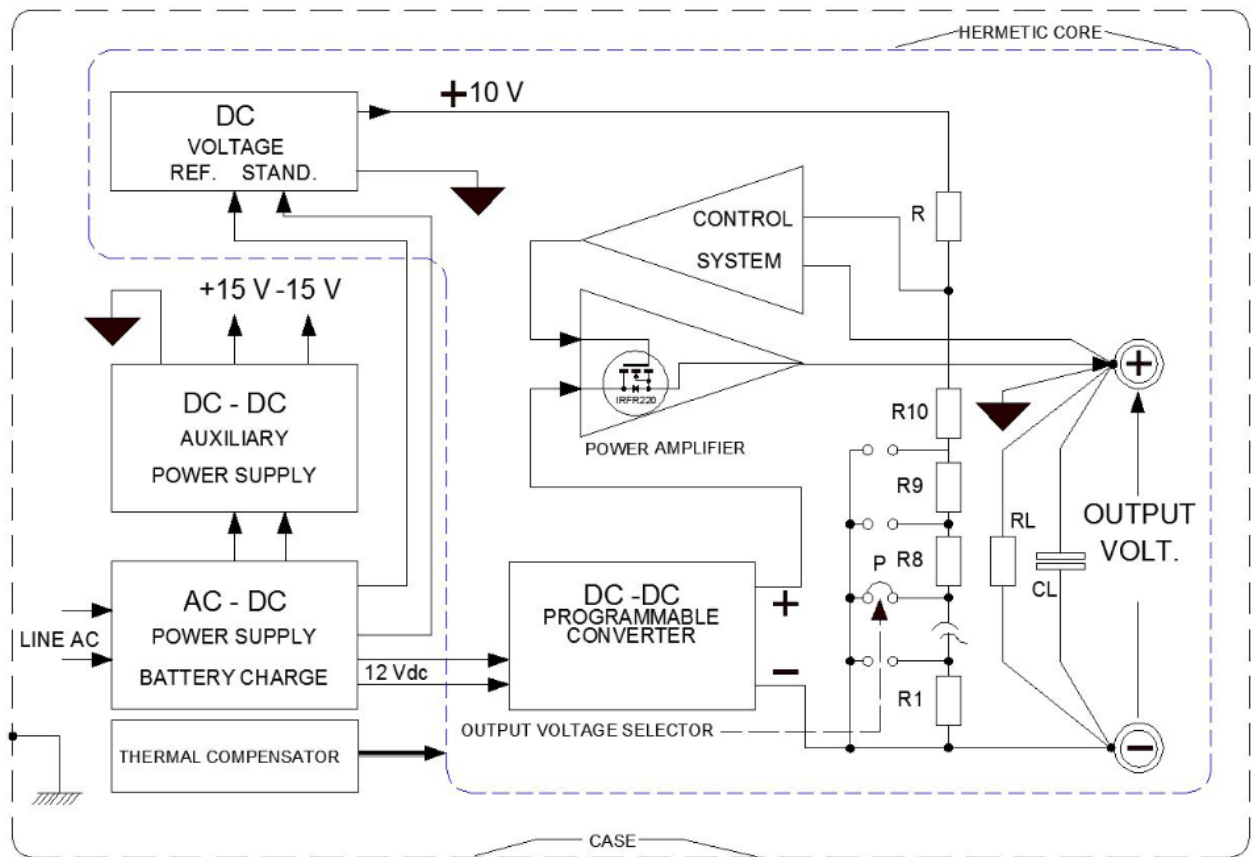
adjusted [8–12]. High accuracy dc voltage standards at values higher than 10 V are instead not available. Modern electrical calibration laboratories are equipped with dc voltage calibrators and multifunction calibrators (MFCs) operating in dc voltages up to 1000 V. These instruments assure satisfactory stability and accuracy, remote control and commercial availability. On the other hand, they can suffer of noise problems at their input stage [13]. In fact, when calibrators are involved in measurement setups with other sensitive instruments, common mode and power supply noises may cause measurement errors in particular at higher voltages due to their many internal circuits. In addition, calibrators can be damaged during transports due to their dimensions and sensitivity to mechanical stresses. To overcome these problems, at National Institute of Metrological Research (INRIM), a modular multi-value high accuracy transportable high dc voltage standard (THVS) operating from 10 V to 100 V in steps of 10 V, was developed. The idea of the realization of the THVS was not to propose the replacement of calibrators in secondary laboratories but the main aim of the development of the THVS was to use it as high accuracy travelling standard in ILCs to check the measurement capabilities of italian calibration laboratories accredited in dc voltage with very small uncertainties (typically ranging from  $0.5 \times 10^{-6}$  to  $3.9 \times 10^{-6}$  from 10 V to 100 V). These laboratories are in fact equipped with high accuracy voltage dividers as reference standards. The use of the THVS for this kind of ILCs allows to avoid the use of calibrators for the previously mentioned reasons. The THVS can operate connected to the mains or in floating mode connected only to battery reducing noises. In fact, all its circuits can be supplied by means of a set of lead batteries that can be recharged when the device is not involved in measurements. The THVS was built with an electronic technique to improve the accuracy of the high voltages of the THVS. This paper shows the main features of the THVS, its characterization results in comparison with commercial top class dc voltage calibrators and MFCs, its calibration and in use<sup>1</sup> uncertainties as local or transportable standard.

---

<sup>1</sup> We define “in use uncertainty” the effective uncertainty that a standard or instrument introduces, in the time period between two its calibrations, when it is used to calibrate other standards or instruments. It normally includes uncertainty

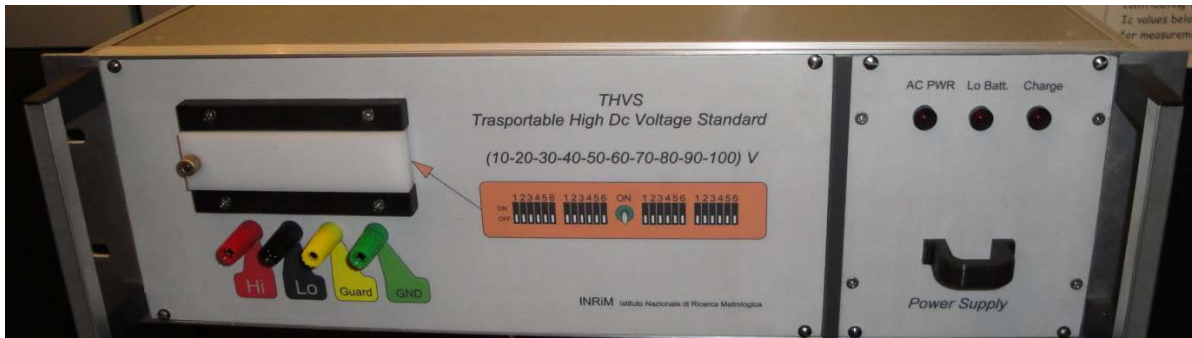
## 2. Description of the THVS

The THVS is equipped with a commercial circuit acting as internal voltage reference (10 Vdc), with temperature coefficient (TCR)  $<0.3 \times 10^{-8}/^{\circ}\text{C}$  and an estimated stability of  $\pm 0.5 \times 10^{-6}/\text{year}$ . A principle scheme of the THVS is shown in Fig.1 where we can see that the THVS is also equipped with a voltage divider R1, ....., R10 to provide the output voltages. As the current flowing in R is constant and it is the same flowing in R1, ....., R10, the voltage drop on the selected resistors establishes the output voltage. The THVS external front view is shown in Fig. 2.



**Fig. 1.** THVS principle scheme.

components due to its calibration, drift, environmental conditions and other influence parameters dependence. Similar concept is given in [14]. In use uncertainties can be compared with accuracy specifications of calibrators.



**Fig. 2.** Front view of the THVS.

The THVS receives the correct supply voltages by means of precision low-ripple DC-DC PROGRAMMABLE DC-DC CONVERTER to obtain the selected output voltages. An AC-DC POWER SUPPLY–BATTERY CHARGE provides an accurate dc voltage of 12 V assuring a correct supply of the DC-DC CONVERTER. The output stage employs a high voltage N-channel MOS component as POWER AMPLIFIER. An additional low noise and high insulation DC-DC AUXILIARY POWER SUPPLY with outputs of  $\pm 15$  Vdc provides auxiliary voltages to control the output stage. The control circuits are made with precision instrumentation amplifiers. The resistors of the internal divider are hermetically sealed high-precision Z-Foil with TCR lower than  $0.4 \times 10^{-6}/^{\circ}\text{C}$ . The output stage is equipped also with a protection system for maximum voltage and current. It was utilized a ground-mobile technique to control the generated voltages that is visible in Fig. 1 where the internal ground potential is driven to the positive potential of the output selected voltage making easier its control and improving its stability. In addition, this technique allows to use components normally utilized for low voltages available at lower cost. The electrical power required by the circuitry to control the electrical output of the THVS is supplied by three rechargeable sealed lead 6 V 5Ah batteries that ensure to the THVS an autonomous operation of some hours.

### 2.1. THVS components and characteristics

The resistors  $R, R_1, \dots, R_{10}$  involved in the THVS are Vishay VSRJ type  $10 \text{ k}\Omega$  with tolerance of  $\pm 0.05 \%$ , TCR lower than  $0.4 \times 10^{-6}/^{\circ}\text{C}$ , thermal electromotive force (EMF) of  $\pm 0.05 \mu\text{V}$  in the

temperature range of  $(23 \pm 1 \text{ }^\circ\text{C})$  typical of electrical calibration laboratories, power at  $70^\circ\text{C}$  of  $\cong 0.3 \text{ W}$ . For the 10 V and 20 V were inserted two Vishay VH102Z type  $10 \text{ k}\Omega$  with same tolerance and power but with TCR lower than  $0.2 \times 10^{-6}/^\circ\text{C}$  to improve the stability of these two values of the THVS that are the most critical values. The main electronic component, inserted in the POWER AMPLIFIER (Fig. 1), is a Hexfet MOSFET VISHAY mod. IRFR220 with  $V_{\text{drain-Source(DS)}}$  of 200 V,  $R_{\text{DS on}}$  of  $0.8 \text{ }\Omega$  and  $I_{\text{DSon}}$  of 3A. This power stage operates at a constant power regardless of the set output voltage. Other significant components are:

- An encapsulated DC-DC PROGRAMMABLE CONVERTER EMCO mod. CA02 P (Fig. 1) with output from 18 V to 110 Vdc with instability  $< 25 \times 10^{-6}/^\circ\text{C}$ , peak to peak ripple at full load:  $< 0.01\%$ , frequency from 80 kHz to 180 kHz and high insulation;
- A CONTROL SYSTEM (Fig. 1) for the power section made with ultraprecision operational amplifiers with offset voltage  $< 10 \text{ }\mu\text{V}$ , offset drift  $< 0.1 \text{ }\mu\text{V}/^\circ\text{C}$ );
- AC-DC POWER SUPPLY –BATTERY CHARGE with noise voltage  $\cong 30 \text{ }\mu\text{V}$  peak to peak (pp), TCR  $\cong 1 \times 10^{-5}/^\circ\text{C}$  and output current of 0.5 A.

The gain of CONTROL SYSTEM is  $-1$  and the gain of the POWER AMPLIFIER is  $\cong 1000$ .

## 2.2. THVS specifications

The specifications of the THVS are:

- Output voltages: from 10 V to 100 V with steps of 10 V selectable by means of a front panel switch;
- Output currents  $\leq 5 \text{ mA}$ ;
- Output noise, evaluated in the band from 0.1 Hz and 10 Hz at 100 V,  $\leq 6.9 \text{ }\mu\text{V}$  rms operating connected to the mains and  $\leq 5.0 \text{ }\mu\text{V}$  operating connected only to battery to be compared with  $155 \text{ }\mu\text{V}$  and  $153 \text{ }\mu\text{V}$  of a top class dc voltage calibrator and a top class MFC as declared by the manufacturers;

- Evaluated 24h mean stability of  $1.2 \times 10^{-8}$  at 100 V to compare with  $3.8 \times 10^{-7}/24\text{h}$  and  $5.0 \times 10^{-8}/24\text{h}$  of two top-class dc voltage calibrators and with  $1.0 \times 10^{-7}/24\text{h}$  and  $2.5 \times 10^{-7}/24\text{h}$  of two top-class MFCs;
- Evaluated long-term drift of  $2.6 \times 10^{-6}$  at one year at 100 V.

The THVS has better accuracy at higher values as the voltage sensitivity of the CONTROL SYSTEM (Fig. 1) more affects the precision of the output voltage when this value is decreased.

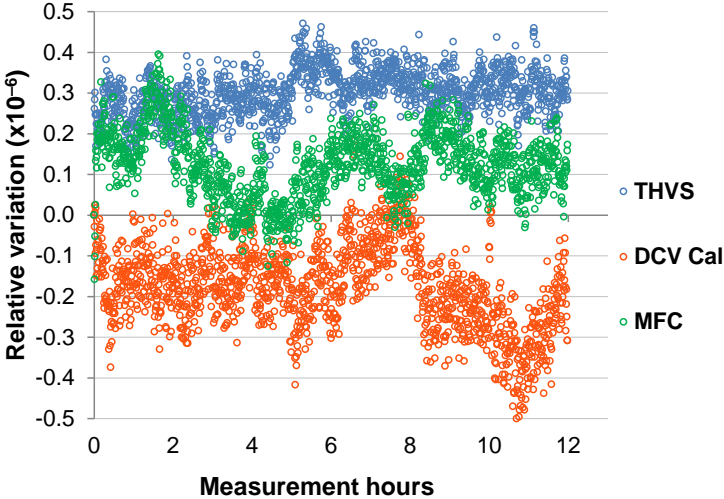
### 2.3. Thermal features of the THVS

To investigate the temperature behaviour of the THVS in the typical temperature range of electrical calibration laboratories, its temperature coefficient around 23 °C was evaluated soon after its assembly. The THVS was measured, after suitable stabilization, at (22, 23 and 24) °C in a settable temperature laboratory. The temperature coefficient resulted  $\cong - 1.0 \times 10^{-7}/^\circ\text{C}$ . To further minimize the temperature dependence of the THVS, a thermal compensator maintaining the temperature inside the THVS hermetic core (grey-shorter-dashed line in Fig. 1) at 37.7 °C was added. This thermal compensator rejects the temperature changes due to different load effects of the different voltages and due to the external temperature variations. By means of it, the temperature fluctuation in the THVS core is maintained within  $\pm 0.15$  °C at the temperature conditions of an electrical laboratory lowering the corresponding uncertainty component. With the action of the thermal compensator a faster stabilization of a new selected voltage can be achieved and the humidity dependence of the THVS core is minimized, as it is permanently maintained, regardless of the set output voltage, at a temperature that can dry eventual moisture traces.

### 3. Comparison with top-class DC voltage calibrators and MFCs

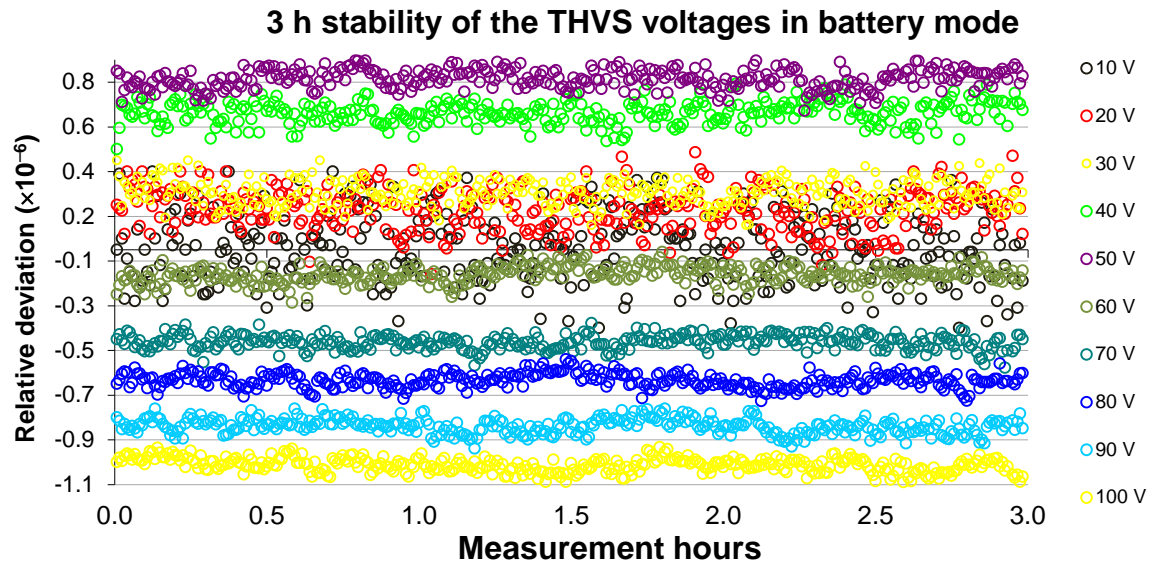
Two alternative tests were carried out to compare the THVS at 100 V with high accuracy dc voltage calibrators and MFCs in their dc voltage mode. In the first test, the THVS was

compared with a high performance dc voltage calibrator and a high performance MFC at 100 V connecting them alternatively to the same high accuracy digital multimeter (DMM) after a same stabilization period. The DMM measurements at 100 V were computed nulling its 0 V readings. The measurements were made in a shielded laboratory thermo-regulated at  $(23 \pm 0.3) ^\circ\text{C}$  and at a relative humidity of  $(40 \pm 10) \%$ . The 12h measurement results of the three standards are shown in Fig. 3. In this case the THVS was connected to the mains. The measurements relative spreads, evaluated as standard deviations, were  $3.9 \times 10^{-8}$ ,  $1.0 \times 10^{-7}$  and  $8.3 \times 10^{-8}$  respectively for the THVS, for the dc voltage calibrator and for the MFC. These values included the DMM contribution that was considered stable in the three evaluations as the better available DMM was selected. The lowest drift, considered as deviation from perfect value stability, was obtained by the THVS. In Fig. 4 the 3h measurement drift of all the dc voltages provided by the THVS in floating mode (only battery-fed) are reported. This time was chosen as it is the typical time necessary to calibrate dc voltage standards in floating mode. The lowest relative spread ( $3.2 \times 10^{-8}$ ) was obtained at 100 V confirming the better stability and lower noise of the THVS operating in battery mode.



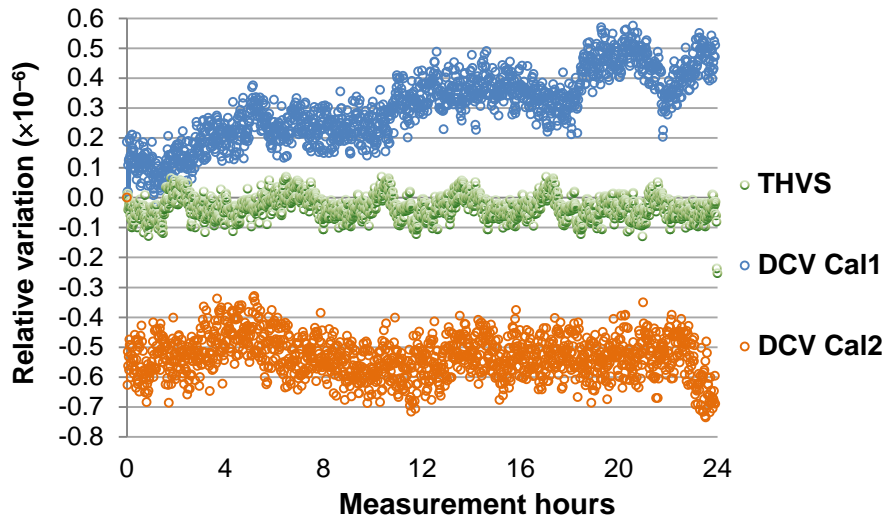
**Fig. 3.** 12h relative spread and drift comparison among the THVS, a dc voltage calibrator and a MFC at 100 V reading with a high precision DMM.



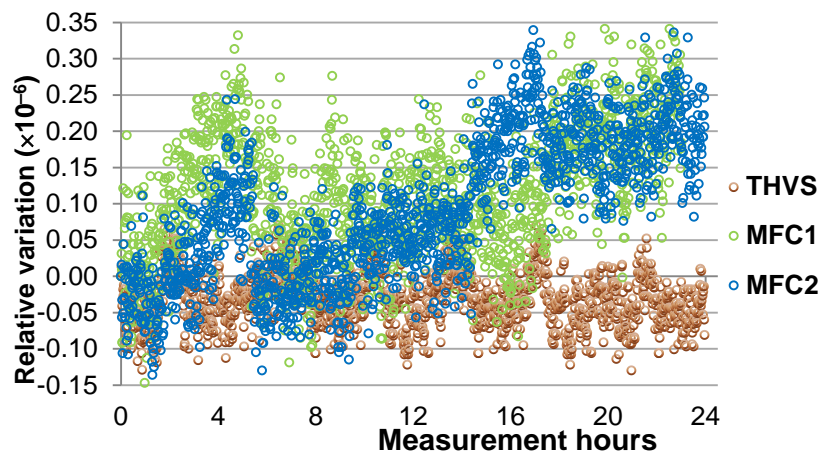


**Fig. 4.** 3h stability comparison among the dc voltages of the THVS operating in battery mode.

With the second test, three DMMs with similar noise and intrinsic repeatability were selected. The THVS was compared at 100 V with two top class dc voltage calibrators (Fig. 5) then with two top class MFCs (Fig. 6) in a 24h time-period after a same stabilization period. The comparison were made connecting the instruments at the same time to the three selected DMMs. The measurements were carried out during the weekend to avoid disturbs due to presence of the operators. In these measurements the compared instruments were subjected to the same environmental fluctuations. The THVS was connected to the mains. In the first case the relative spreads were  $3.6 \times 10^{-8}$ ,  $1.2 \times 10^{-7}$  and  $6.8 \times 10^{-8}$  respectively for the THVS and for the two dc voltage calibrators. The lowest drift, was obtained by the THVS with a relative deviation of  $1.1 \times 10^{-8}/24\text{h}$  vs.  $3.8 \times 10^{-7}/24\text{h}$  and  $5.0 \times 10^{-8}/24\text{h}$  for the two dc voltage calibrators.



**Fig. 5.** 24h relative spread and drift of the THVS and of two dc voltage calibrators at 100 V with the three DMMs test.



**Fig. 6.** 24h relative spread and drift of the THVS and of two MFCs at 100 V with the three DMMs test.

In the second case the relative spreads were  $3.7 \times 10^{-8}$ ,  $2.3 \times 10^{-7}$  and  $1.0 \times 10^{-7}$  respectively for the THVS and for the two MFCs. The lowest drift was obtained by the THVS with a relative drift of  $1.2 \times 10^{-8}/24\text{h}$  vs.  $1.0 \times 10^{-7}/24\text{h}$  and  $2.5 \times 10^{-7}/24\text{h}$  for the two MFCs.

The improvement of the stability of the THVS is due to the simplicity of the circuit. MFCs provide any voltage value (and other low frequency electrical quantities) and can be calibrated by means of external voltage standards (artifact calibration). Consequently they are made with several DC-DC converters, AC/DC digital converters, auxiliary powers and microprocessors that can likely disturb one-another causing undesired spike noises. The THVS, not being a calibrator but a multiple value dc voltage standard, was constructed with a technique that is an improvement of that of the

10 V voltage standards limiting at maximum the number of electronic components reducing noises and improving stability. A further confirmation of this principle is given by the fact that even old dc voltage calibrators (with narrower measurement fields and consequently less number of electronic components) have still better dc voltage specifications and stability than modern MFCs.

#### 4. Calibration of the THVS

The THVS is calibrated with a differential measurement method by means of the measurement setup shown in Fig. 7. The THVS is connected to the input of a high accuracy INRIM dc voltage divider [16] set in suitable ratio. Then the divider output voltage is compared with a INRIM Zener 10 V dc Voltage standard calibrated vs. the INRIM national dc voltage standard. Between the divider output and the 10 V voltage standard, a high precision DMM measures the unbalance voltages.

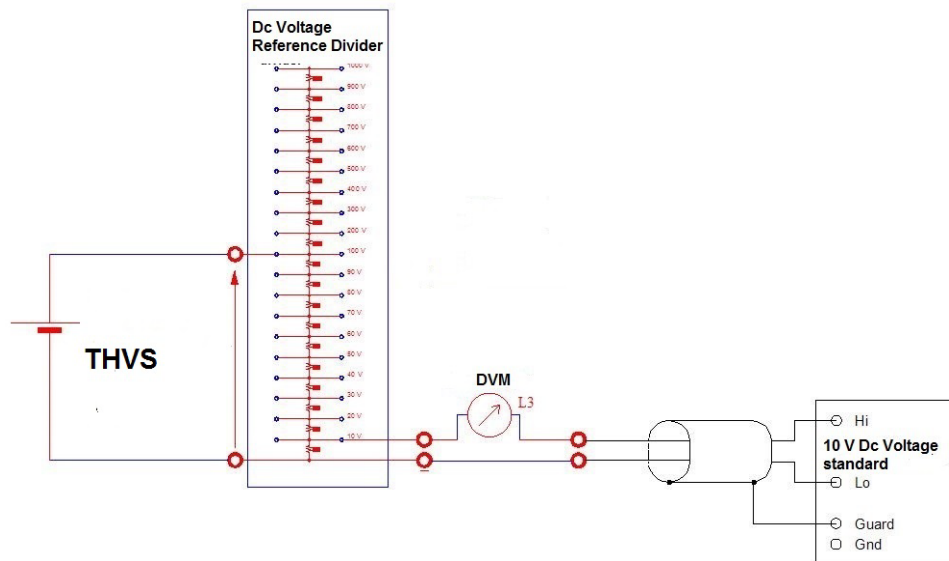
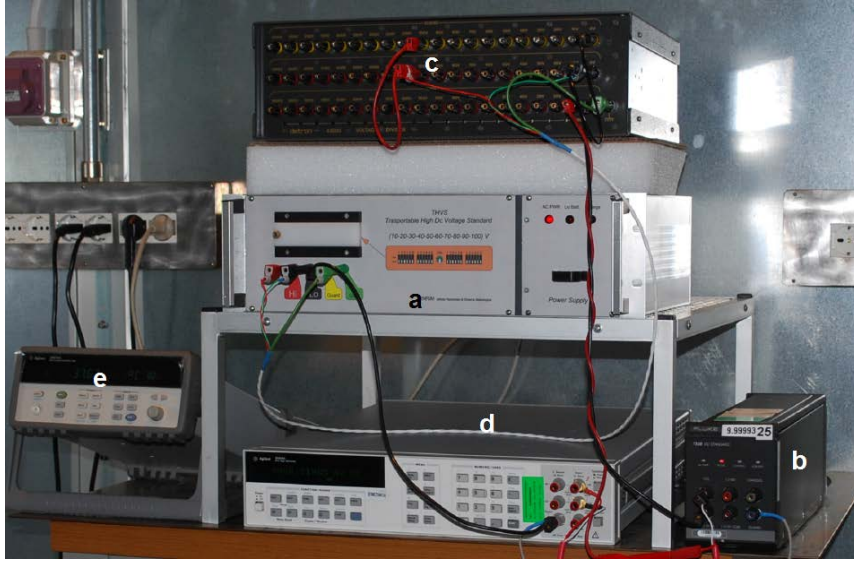


Fig. 7. Measurement setup to calibrate the THVS.

Thus, the THVS value is:

$$V_{THVS} = \frac{V_s + v}{D} \quad (1)$$

where  $V_s$  is the value of the 10 V dc voltage standard,  $v$  the voltage unbalance and  $D$  the divider dc voltage ratio. In Fig. 8 a photo of the measurement setup of fig. 7 is shown.



**Fig. 8.** View of the measurement setup to calibrate the THVS. a) THVS, b) 10 V reference Standard, c) dc voltage standard divider, d) DMM used to measure the unbalance voltages, e) temperature-meter to acquire the temperature inside the THVS.

## 5. Evaluation on the uncertainties of the THVS

### 5.1. THVS calibration uncertainty

According to the paragraph 4 and to (1) in Table 1 a relative uncertainty budget for the calibration of the THVS at 100 V is given. In the calibration sixty automated measurements of the unbalance voltage for both polarities were made.

**Table 1.**  
THVS calibration uncertainty budget at 100 V.

Source ( $X_i$ )	$u(x_i)$ ( $\mu\text{V}$ )	type	$c_i$	$v_i$	$1\sigma$ (abs. unc.) $u(y_i)$ ( $\mu\text{V}$ )	$1\sigma$ (rel. unc.) ( $\mu\text{V}/\text{V}$ )
Reference 10 V calibration	2.5	B	10	$\cong \infty$	25	0.25
Reference drift	0.58	B	10	$\cong \infty$	5.8	0.058
Ref temp. dependence	0.23	B	10		2.3	0.023
Ref humidity dependence	negl	B	10	$\cong \infty$	negl.	negl. <sup>2</sup>
DMM accuracy	0.18	B	10	$\cong \infty$	1.8	0.018 <sup>3</sup>
DMM calibration	0.094	B	10	$\cong \infty$	0.94	0.0094 <sup>3</sup>
Common-mode rejection	1.0	B	10	$\cong \infty$	10	0.1
Unbalance repeatability	0.99	A	10	59	9.9	0.099

<sup>2</sup> The internal dc voltage 10 V reference is a well-characterized commercial INRIM standard that has a negligible humidity dependence as also reported in [15]. In addition, as the reference is inserted in the THVS core is maintained at a constant temperature of 37.7 °C further minimizing its humidity dependence.

<sup>3</sup> The estimate of these two uncertainties was made considering that these components are related to the unbalance voltage measured by the DMM ( $\cong 380 \mu\text{V}$ ) to relate to the THVS 100 V calibration value.

Divider calibration	0.01	B	1000	$\cong \infty$	10	0.1
Divider drift	0.0012	B	1000	$\cong \infty$	1.2	0.012
Divider temp. dependence	0.0012	B	1000	$\cong \infty$	1.2	0.012
Total RSS	$v_{eff} > 50$	$k_p \cong 2$			31	0.31

For a 95 % confidence level the calibration relative uncertainty of the THVS at 100 V is then  $6.2 \times 10^{-7}$ . According to these uncertainty components, in Table 2 the expanded calibration relative uncertainties of the THVS are listed.

**Table 2.**  
THVS calibration relative expanded uncertainty for each voltage.

Voltage (V)	Expanded uncertainty $\mu\text{V/V}$
10	0.72
20	0.71
30	0.70
40	0.68
50	0.66
60	0.65
70	0.64
80	0.63
90	0.62
100	0.62

### 5.2. Long-term stability of the THVS

The THVS was also measured about every week at various voltages with the measurement setup of Fig. 8 to evaluate its mid-term stability. In fig. 9 the THVS drift at 100 V is reported. It showed a smooth linear decreasing drift of  $2.6 \times 10^{-6}$  in a year. This drift can be presumably due to the incomplete stabilization of the THVS internal components. The measurements will continue to establish the long-term regimen drift of the THVS.

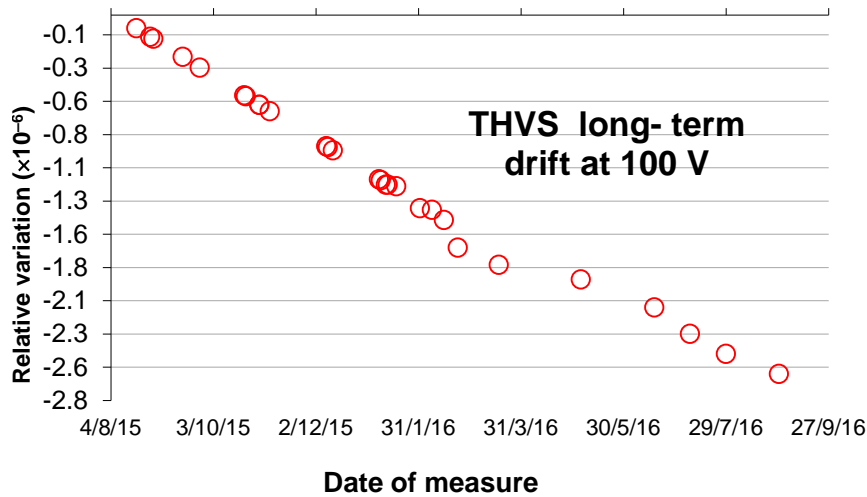


Fig. 9. Drift of the THVS at 100 V since its construction.

### 5.3. In use uncertainty of the THVS

in Table 3 a relative in use uncertainty budget of the THVS at 100 V is reported. It was assumed to consider the THVS as dc voltage standard for a year without re-calibration. The in use uncertainties of the THVS can be regarded as its the accuracy specifications.

**Table 3.**  
THVS in use uncertainty budget at 100 V.

Source	$u(x_i)$ ( $\mu\text{V}$ )	type	$c_i$	$\nu_i$	1 $\sigma$ (abs. unc.) $u(y_i)$ ( $\mu\text{V}$ )	1 $\sigma$ (rel. unc.) ( $\mu\text{V}/\text{V}$ )
calibration	29	B	1	$\cong \infty$	29	0.29
drift	0.75	B	100	$\cong \infty$	75	0.75 <sup>4</sup>
Temp/hum/dependence	0.0012	B	100	$\cong \infty$	0.12	0.0012
noise	0.069	B	100	$\cong \infty$	6.9	0.069
<b>Total RSS</b>			$\nu_{\text{eff}} > 50$	$k_p \cong 2$	81	0.81

For a 95% confidence level the in use relative uncertainty of the THVS at 100 V is then about  $1.6 \times 10^{-6}$ . According to these uncertainty components, in Table 4 the expanded relative in use uncertainties of the THVS are listed. These uncertainty values are valid using the THVS as laboratory standard till to one year after calibration. These uncertainties are better than the one-year accuracy specifications of dc voltage calibrators and MFCs in their dc voltage function in particular at higher voltages.

<sup>4</sup> This uncertainty component was evaluated according to [17], clause F.2.2.2.

**Table 4.**

THVS in use relative expanded uncertainties as laboratory standard for each voltage.

Voltage (V)	Expanded uncertainty $\mu\text{V/V}$
10	3.6
20	3.3
30	3.1
40	2.9
50	2.7
60	2.5
70	2.4
80	2.1
90	2.0
100	1.6

#### 5.4. Transport effect on the THVS

In a hypothetical ILC the THVS could be transported by car, van, or plane and maintained for several hours or some days in not controlled environment conditions till to the arrival to the participating laboratories. In our test, the THVS was measured at INRIM before the transport; after it was transported in a suitable package by car with 2-3h of travel, successively maintained in uncontrolled temperature condition for at least 24h. Then it was placed in a thermo-regulated laboratory for 24h before to be measured again. The observed maximum relative difference between the measurements made before and after the transport, analysing all voltages, was  $2.0 \times 10^{-7}$ . For each voltage provided by the THVS was made a complete calibration as described in par. 4 performing sixty measurements of the unbalance voltage for both polarities. In Table 5 the in use relative uncertainties as transportable standard, obtained adding to the in use ones as laboratory standard, the transport uncertainty component, are listed.

**Table 5.**

THVS relative expanded use uncertainties as transportable standard for each voltage.

Voltage (V)	Expanded uncertainty $\mu\text{V/V}$
10	3.6
20	3.4
30	3.2
40	3.0
50	2.8
60	2.6
70	2.5
80	2.1

90	2.0
100	1.7

Nevertheless, in a hypothetical ILC involving several laboratories with the THVS as transportable standard the use uncertainties can be significantly lowered if the ILC's reference measurements provider [18] checks periodically the THVS drift in order to correct its voltage values at the dates of the other participants at the ILC.

## 6. Conclusions

As it can be seen in Tables 2 to 5 the THVS shows better accuracy increasing the output voltage. In the characterization and stability tests it showed lower noise, better short and mid-time stability and measurement repeatability than top class dc voltage calibrators and MFCs. In addition, its in use uncertainties are better than the accuracy specifications of top-class calibrators. This is a significant result although the THVS case is not actively thermo-regulated for example with a Peltier device that would assure further temperature stabilization with respect temperature fluctuations of the laboratory environment. The THVS is then suitable to act as dc voltage laboratory standard or transportable multiple-value standard for national ILCs.

THVS performance is actually limited by the incomplete thermo-regulation of the THVS case (longer-black dashed line in Fig. 1). Hopefully, better stability will be reached with the ageing components. Nevertheless, stability may be limited by the use in different environment conditions during ILCs and how it is transported and maintained.

Future aim will be the evaluation of the THVS pressure dependence for its possible involvement also in international ILCs. In a few months, the THVS will be involved in an ILC among INRIM and some high level accredited italian secondary laboratories. This ILC will be a further occasion to verify the stability, transport effect and environmental dependence of the THVS. The THVS project is extensible in future adding to the current device a module with a voltage source providing a dc selectable voltage ranging from 100 V to 1000 V with steps of 100 V and with a complete active thermo-regulation.



## Acknowledgements

The authors wish to thank F. Francone for his help in the construction of mechanical details of the THVS.

## References

- [1] R. Pöpel, The Josephson Effect and Voltage Standards, *Metrologia* 29 (1992) 153–174.
- [2] L. Huntley, A Primary Standard of Voltage Maintained in Solid-State References, *IEEE Trans. Instrum. Meas.* IM-36 (4) (1987) 908–912.
- [3] T.J. Witt, Maintenance and dissemination of voltage standards by Zener-diode-based instruments, in: *IEEE Science, Measurement and Technology*, 149 (6) 2002, pp. 305–312.
- [4] D.Reymann, et al., Recent developments in BIPM voltage standard comparisons, *IEEE Trans. Instrum. Meas.* 50 (2) (2005) 215–221.
- [5] C. A. Hamilton, Interlaboratory Comparison at 10 V DC, *IEEE Trans. Instrum. Meas.* 54 (1) (2001) 206–209.
- [6] V.Graetsch, E.Staben, H. Bachmair, An international comparison of dc voltage at 1 V and 10 V using solid-state reference standards, in: *Prec. El. Measur. Conf.CPEM*, Ibaraki, Japan, 1988, pp. 14–15.
- [7] L.S.R. Becker, B.F.Field, T.E. Kiess, Round-Robin Test Conducted on a Solid-State DC Voltage Standard, *IEEE Trans. on Instrum. Meas.* 48 (2) (1986) 383–386.
- [8] Fluke Corp. *Calibration: Philosophy in Practice*, 2nd ed, 1994.
- [9] Agilent Technologies, *3458 Multimeter User's Guide*, ed. 4, 2000.
- [10] Fluke Corp. *5700A/5720A Series II Multi-Function Calibrator Service Manual*, rev. 1, 3/02, 1996.
- [11] G. Rietveld, *Artifact calibration: An evaluation of the Fluke 5700A series II calibrator*, Rep. ISBN 90-9\0013\0322-4, 1999.
- [12] P.P. Capra, F. Galliana, 1  $\Omega$  and 10 k $\Omega$  high precision transportable setup to calibrate multifunction electrical instruments, *Measurement* 82 (2016) 367–374.
- [13] L.Callegaro, V. D'Elia, P. P.Capra, A. Sosso, Techniques for Traceable Measurements of Small Currents, *IEEE Trans. Instrum. Meas.*, 56 (1) (2007) 295–299.

- [14] W. Bich, F. Pennechi, On the in-use uncertainty of an instrument, in: P. Ciarlini, M. G. Cox, E. Filipe, F. Pavese, D. Richter (Eds), *Advanced Mathematical & Computational Tools in Metrology*, World Scientific, Singapore, 2004, pp. 59–169.
- [15] T. J. Witt, D. Reymann, and D. Avrons, The Stability of Some Zener-Diode-Based Voltage Standards, *IEEE Trans. Instrum. Meas.*, 44 (2) (1995) 226–229.
- [16] G. Marullo Reedtz, R. Cerri, Characterization of the Travelling Standard for an International Comparison of DC Voltage Ratio, *IEEE Trans. Instrum. Meas.* 48, (2) (1999) 338–341.
- [17] JCGM 100:2008. Evaluation of measurement data— Guide to the expression of uncertainty in measurement, (GUM), 1st edition, 2008.
- [18] EN ISO/IEC 17043:2010 “Conformity assessment – General requirements for proficiency testing”.