



ISTITUTO NAZIONALE DI RICERCA METROLOGICA Repository Istituzionale

Automated precision DC voltage fixed ratios divider

This is the author's accepted version of the contribution published as:

Original

Automated precision DC voltage fixed ratios divider / Galliana, Flavio; Capra, Pier Paolo; Cerri, Roberto; Lanzillotti, Marco. - In: MEASUREMENT. - ISSN 0263-2241. - 122:(2018), pp. 291-296.
[10.1016/j.measurement.2018.03.045]

Availability:

This version is available at: 11696/57785 since: 2021-03-05T18:33:22Z

Publisher:

Elsevier

Published

DOI:10.1016/j.measurement.2018.03.045

Terms of use:

This article is made available under terms and conditions as specified in the corresponding bibliographic description in the repository

Publisher copyright

(Article begins on next page)

AUTOMATED PRECISION DC VOLTAGE FIXED RATIOS DIVIDER

Flavio Galliana¹, Pier Paolo Capra², Roberto Cerri³ and Marco Lanzillotti⁴

^{1,2,3,4}) *National Institute of Metrological Research, strada delle Cacce 91, 10135 TURIN – Italy*

¹Phone + 39 011 3919336, fax + 39 011 346384 f.galliana@inrim.it

²Phone + 39 011 3919424, fax + 39 011 346384 p.capra@inrim.it

³ Phone + 39 011 3919426, fax + 39 011 346384 r.cerri@inrim.it

⁴ Phone + 39 011 3919315, fax + 39 011 346384 m.lanzillotti@inrim.it

ABSTRACT

At the National Institute of Metrological Research (INRIM), an automated precision DC voltage fixed-ratios divider allowing the division ratios 10:1 and 100:1 has been built. It is made utilizing one hundred selected bulk metal foils 10 k Ω resistors with low temperature coefficient. Being the instrument inter-connectable to a multi-meter (DMM) characterized in linearity on the 10 V range and to a DC voltage generator, it can be quickly and automatically calibrated when necessary. This calibration method has been validated by comparing it with another method involving the INRIM DC voltage ratio standard. Other achievement is that the characterization of the linearity of the DMM on the 10 V range allow considering in the uncertainties budget of the calibration of the divider, the uncertainties of the linearity characterization of the DMM instead of its much larger accuracy specifications. The expanded uncertainties of the calibration of the 10:1 and 100:1 ratios are respectively 4.6×10^{-7} and 6.6×10^{-7} , suitable to employ the divider in an automated measurement setup with a DMM and a DC voltage standard to calibrate DC voltage generators as top-level calibrators, widespread in secondary electrical laboratories.

Keywords: DC voltage divider, DC voltage ratio, DC voltage generator, calibration, multi-meter, measurement uncertainties, measurement comparison.

1. INTRODUCTION

Multi-meters (DMMs) and high-precision DC voltage dividers are often involved in measurement setups to calibrate DC voltage or multifunction generators [1]. National and high

level secondary laboratories have used for this activity commercial high precision manually operating DC voltage dividers [2, 3]. Anyway, the interest in realizing and using DC voltage dividers has been wider. Effective guarded dividers were developed for high accuracy DC voltage applications [4, 5] and also for high voltages [6–10]. Since the calibration of manually operating dividers requires a lot of time, at the National Institute of Metrological Research (INRIM) an automated resistive DC voltage fixed-ratios divider has been developed. This instrument (external view in Fig.1) allows the 10:1 and 100:1 division ratios and can be quickly calibrated interconnecting it to a DC voltage generator and to a DMM characterized in linearity. This calibration lasts about one hour **taking advantage also of** a 100:10 ratio while for the calibration of a manually operating divider at least two working days are necessary with the constant presence of the operator introducing undesired noises. As the INRIM divider can be also interconnected with a 10V reference standard, it could be further employed in a measurement system for the calibration of DC voltage generators from 1 mV to 1 kV.

2. THE INRIM DIVIDER-INSTRUMENT

The components of the instrument are: a resistive divider, a low-power and low electromotive forces (emfs) a switching system and an IEEE488.2 interface control system. Additional components are a logic control card and a device to check periodically the status and operation of the relays. It was projected as bench instrument and therefore it was inserted into a 19-inch three units rack case.

2.1 The resistive divider

The resistive divider is made combining one hundred bulk metal foil 10 k Ω Vishay resistors in three series (R, 9R and 90R shown in Fig. 2 and 3A) selected in groups of ten (sets). A detail of two resistors is given in Fig. 3B. These resistors were chosen as suitable to employ at 23 °C. They are metal lamina film resistance elements deposited on a ceramic support. Their temperature coefficient (TCR) is negligible from 18 °C to 30 °C as their support produces a twist proportional to the film temperature of the resistor compensating resistance variations. In order to minimize residual

uncompensated resistances, the selection of the resistors in sets of ten further lowers the effect of the different dependence vs. temperature of the resistors. To form the set(s), the available resistors were measured with a high precision DMM and were selected at $\pm 1.0 \times 10^{-3}$ vs. their nominal value and within $\pm 5 \times 10^{-4}$ each other.



Fig. 1. External view of the INRIM divider instrument. A 19" case holds two copper boxes, one with the resistive divider and the other with the relays system, a GPIB I/O interface and the power supply.

Ten resistors sets were formed at a matching level among them of 6×10^{-7} . In addition, the first set (used for the 10:1 ratio) was put in a thermostatic air-bath and its resistors were accurately measured at the temperatures from 18 °C to 27 °C. As one resistor maintained its value within $\pm 0.1 \times 10^{-6}$ in this temperature range, was chosen as R. All the resistors were mounted on printed circuit boards having comb shape to increase the insulation. The combs were mounted on Teflon supports fixed on a copper box (Fig. 3A).

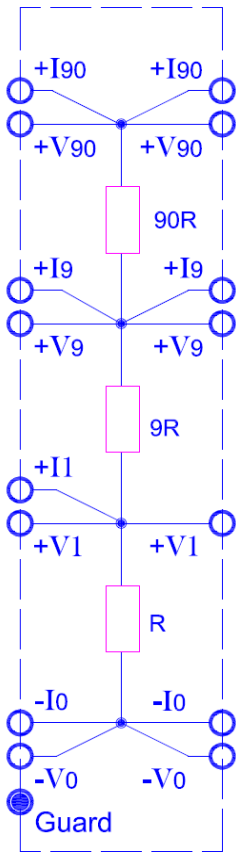

Fig. 2. Scheme of the resistive divider. +V and -V are respectively the positive and negative voltage terminals (sense) while +I and -I are the positive and negative current terminals. The left side of the divider has to be connected to the DC voltage generator while the right side has to be connected to the DMM or eventually to a DC voltage standard.

Being this copper box further placed into a case connected to the ground potential, the instrument is shielded from electrostatic and electromagnetic fields. The connections cables are multi-wire silvered copper ones with high insulation Teflon sheaths. Gold-tellurium plated binding post were chosen as external connectors to reduce noises and emfs.

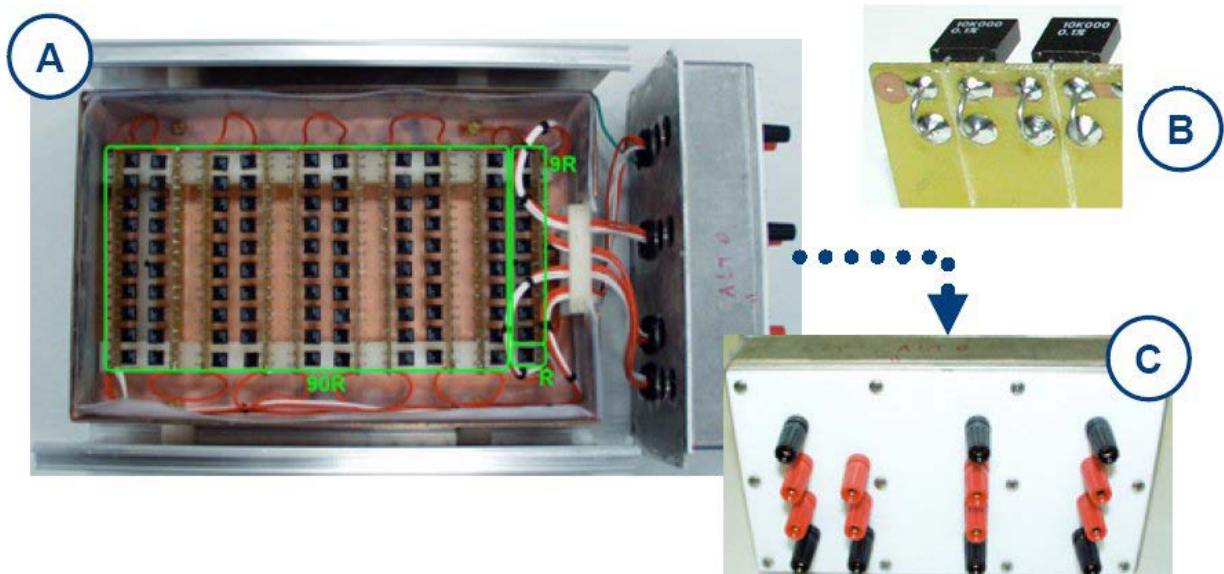

Fig. 3. Mechanical configuration of the INRIM resistive divider: A) the three resistors series; B) detail of a set of resistors. These are soldered in four terminal configuration. Cuts perpendicular to the resistors terminals were made to enhance the insulation of the support; C) panel (also visible in Fig. 5, left side) supporting the inner divider connections. These are fixed on the copper box and come out from the front panel by means of a DELRIN adaptation to utilize the total length of the connectors.

2.2 The relay-based switching system

A 1.5 mm thick Teflon support, tensed on a brass chassis, is fixed to another copper box (Fig.

4A) on which, in turn, are inserted ten bistable relays with low emfs. These relays (*4 A polarized high density relay with high sensitivity*) allow the remote selection of the series of the divider through a GPIB interface. A capacitive circuit optimizes the DC decoupling between the relays and the GPIB interface outputs. The connections from the relays to the resistive series were shortened as much as possible minimizing the number of welds and were used cables with low resistivity. The relays system is electrically shielded. From the performed tests, the relays have a contact resistance less than $10\text{ m}\Omega$, suitable for our scope. Each component was accurately washed with isopropyl alcohol and dried before the wiring process unlike industrial processes. This operation minimizes the contamination due to residual impurities on the surfaces of the electrical substrates due to the soldering **that could worsen the insulation.**

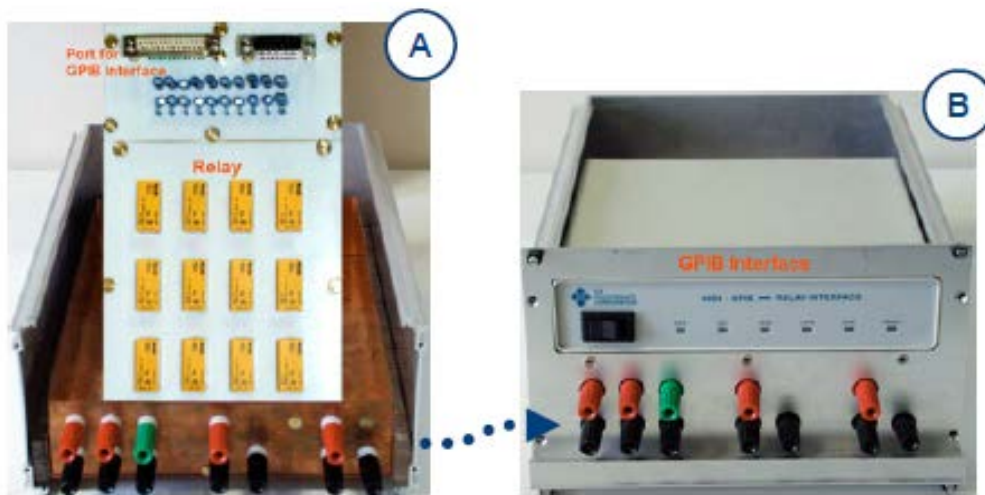

Fig. 4. A) Mechanical configuration of the bistable relays and B) their assembly with the GPIB interface.

Over the relays box, the GPIB interface is placed. A PT100 temperature sensor measures the temperature during the use of the instrument. Fig. 5 shows the connections between the resistors series box and the relays-system box.

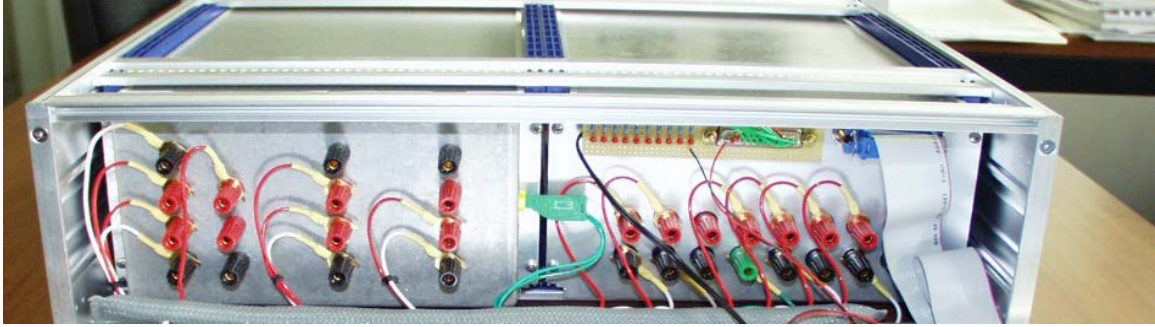

Fig. 5. Rear view of the instrument without the rear panel. It can be seen the connections between the terminals from the resistors series box the to the relays box.

3. QUICK CALIBRATION OF THE DIVIDER

It is possible to calibrate the divider when necessary updating the values its division ratios. A quick calibration can be made with the setup of Fig. 6. This setup involves a DMM HP 3458A [11], characterized in linearity on its 10 V range according to the suggestion of [12, 13] and a J. Fluke 5700A calibrator [14] as high stability DC voltage generator. With the automatic procedure the 10:1 and 100:10 ratios can be calibrated. The control program sets the desired ratio and the calibration sequence providing the mean value and the standard deviation of the mean of the measurements. The 10:1 ratio is obtained by applying a DC voltage of 10 V from the generator on 10R (Fig. 2) and switching the DMM between 10R and R. The DMM measures the voltage drops on 10R and R on the 10 V range. The 100:10 ratio value is obtained by switching a DC voltage of 100 V from the generator between 100R and 10R and reading with the DMM on R, still on the 10 V range. The 100:1 ratio value is obtained from the 10:1 and 100:10 ratio values.

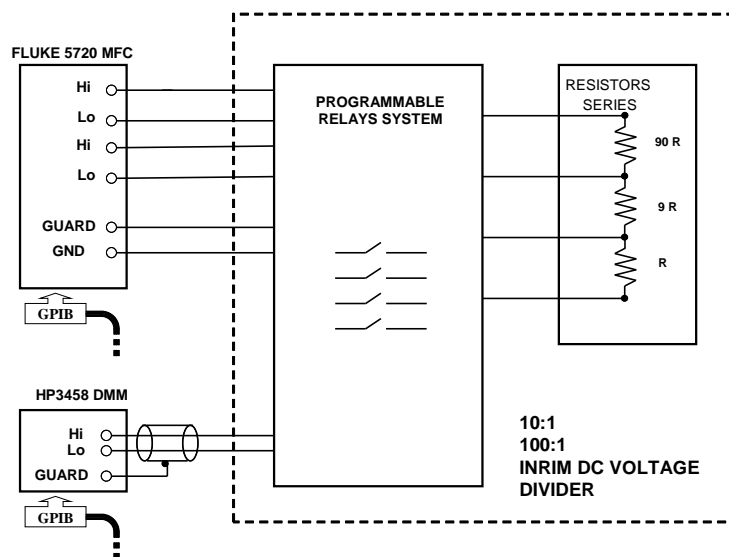

Fig 6. Measurement circuit for the quick calibration of the INRIM divider.

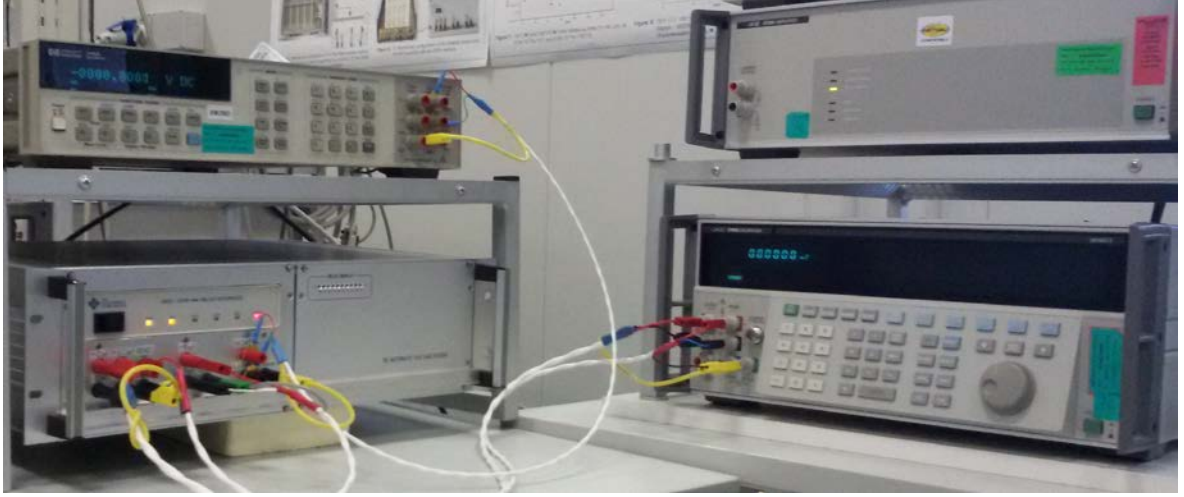

Fig.7. Photo of the measurement setup to quickly calibrate the INRIM fixed-ratios.

3.1 Measurement procedure

For the calibration of the 10:1 ratio of the divider, the measurement program sets the dc voltage generator at 10 V applying this voltage on 10R of the divider (Fig. 2, left side) while the DMM, after suitable waiting times, reads the voltage on 10R (Fig. 2, right side) and successively the voltage on 1R. The same procedure is repeated at -10 V to reduce the offset effects. For the calibration of the 100:10 ratio, the program sets the generator at 100 V applying this voltage on 10R of the divider while the DMM, after suitable waiting times, reads the voltage on 1R. Successively, the generator applies the same voltage on 100R while the DMM reads the voltage still on 1R. The same procedure is repeated at -100 V. The unknown ratio values are given meaning the values at both polarities from the following relation:

$$R = \frac{L_{10}}{L_1} \quad (1)$$

where $R \cong 10$ is the ratio value (10:1 or 100:10) while $L_{10} \cong 10$ V and $L_1 \cong 1$ V are the mean voltage readings by the DMM.

3.2 Uncertainties of the quick calibration method of the divider

To take into account all the the input quantities in the uncertainty budget for the quick calibration of the divider, the (1) can be re-written as:

$$R = \frac{L_{10} \varepsilon_{lin10} \varepsilon_G \varepsilon_{emf10}}{L_1 \varepsilon_{lin1} \varepsilon_{emf1}} \cdot \varepsilon_{Vc} \cdot \varepsilon_{load} \quad (2)$$

where:

$\varepsilon_{lin10} \cong \varepsilon_{lin1} \cong 1$ are the corrections due to the characterization of the DMM linearity respectively at 10 V and 1 V;

$\varepsilon_{mf10} \cong \varepsilon_{mf1} \cong 1$ are the corrections due to the emfs of the circuit when the DMM measures respectively 10 V and 1 V;

$\varepsilon_G \cong \varepsilon_{Vc} \cong \varepsilon_{load} \cong 1$ are respectively the corrections due to the stability of the dc voltage generator, to the voltage coefficient of the divider and to the load effect at the DMM input.

Taking advantage of the characterization of the linearity of the DMM on the 10 V range it is possible consider the uncertainties of this process in the uncertainties budget of the calibration of the divider instead of the much larger DMM accuracy specifications. In Table 1, the standard uncertainties budgets of the quick calibration of the divider 10:1 and 100:10 ratios are given.

Table 1
Standard uncertainties of the divider ratios quick calibration.

10:1 ratio			100:10 ratio		
Uncertainty component	type	1 δ ($\times 10^{-8}$)	Uncertainty component	Type	1 δ ($\times 10^{-8}$)
DMM noise of L_{10}	A	0.5	DMM noise of L_{10}	A	0.5
DMM noise of L_1^1	A	1.5	DMM noise of L_1^1	A	1.5
ε_{in10}	B	negl	ε_{in10}	B	negl.
ε_{in1}	B	19^2	ε_{in1}	B ³	19^2
ε_G	B	2.0	ε_G	B	5.2
ε_{Vc}	B	12	ε_{Vc}	B	12
ε_{mf10}	B	0.2	ε_{mf10}	B	1.7
ε_{mf1}	B	0.2	ε_{mf1}	B	2.9
ε_{load}	B	5.8^3	ε_{load}		Negl.
RSS		23.2			23.2

The standard uncertainty of the calculated 100:1 ratio is 3.3×10^{-7} considering a partial correlation between the 10:1 and the 100:10 ratios evaluations.

3.2 Validation of the process of the divider ratios quick calibration

To validate this method, direct calibrations of the 10:1 and 100:1 ratios were made with a method based on the comparison with the INRIM DC voltage-ratio standard, Datron mod. 4902S reference divider, employed as travelling standard, in the CCEM-K8 comparison [15]. This calibration is performed connecting the fixed-ratios divider to the measurement system by means of the connectors shown in Figs. 3C and 5.

¹ This measurement is also made on the 10 V range of the DMM.

² This value is obtained from the calibration certificate regarding the verification of the DMM linearity on the 10 V range.

³ This component was evaluated considering the input impedance of a specific DMM. The input impedance of the available DMMs model [4] were accurately measured and the item with the higher impedance (about $8.6 \times 10^{11} \Omega$) was enrolled in the measurement setup. For the 100:10 ratio, this component is negligible as the DMM always measures the voltage on R.

4. CALIBRATION METHOD BASED ON THE COMPARISON WITH THE INRIM STANDARD DIVIDER.

Figs. 8 and 9 show respectively the principle scheme to calibrate generic fixed-ratios DC voltage dividers vs. the INRIM standard divider and the setup to calibrate the INRIM fixed-ratios divider. Fig. 10 shows the electrical scheme of the circuit.

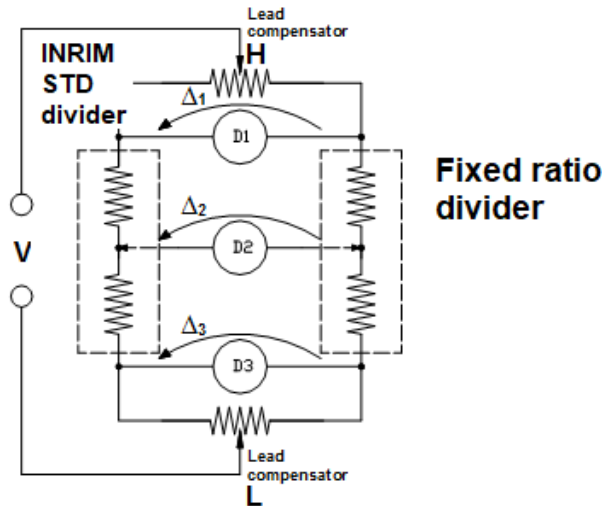

Fig. 8. Principle scheme of calibration of decade DC voltage dividers at the INRIM DC voltage ratio standard.

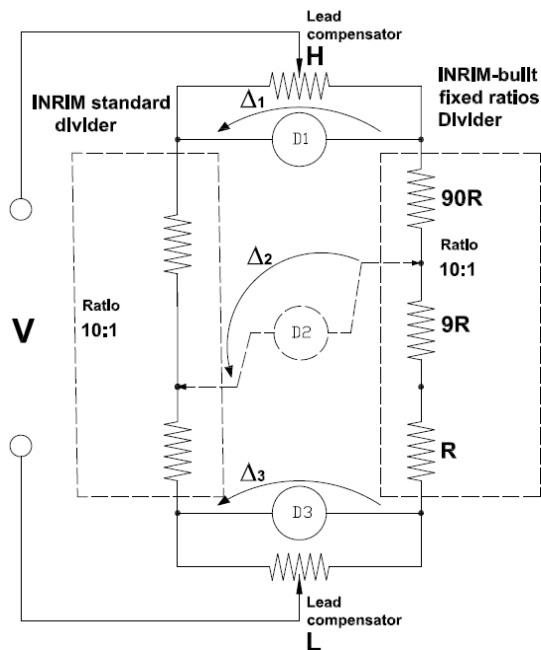

Fig. 9. Measurement setup for the calibration of the INRIM-built DC voltage fixed-ratios divider in the 10:1 ratio.

It is a manually operating method in which the divider under calibration is compared with the standard divider set in the same nominal ratio. By means of three nanovoltmeters D_1 , D_2 , D_3 , the

unknown divider ratio is evaluated. Δ_2 is the voltage reading of D_2 while Δ_1 and Δ_3 are the residual voltages on D_1 and D_3 after the balance with a lead compensator.

4.1 Measurement procedure

The measurement procedure starts, after suitable waiting times, with the zero adjustment of D_1 , D_2 , D_3 at 0 V. Then, at + V, after the adjustment of the lead compensator to null the voltages on D_1 and D_3 (within $\pm 0.2 \mu\text{V}$), the unbalance voltage between the two dividers is measured by means of D_2 . The same two steps are repeated for -V. The unknown ratio is given meaning the values at both polarities obtained from the following relation:

$$F_{Xi} \cong F_{Si} \left(1 - \frac{\Delta_2 / k}{V / F_{Si}}\right) \quad (3)$$

where F_{Xi} and F_{Si} are respectively the ratio values of the divider under calibration and of the standard divider, k the gain of D_2 and V the applied voltage (ranging from 10 V to 100 V).

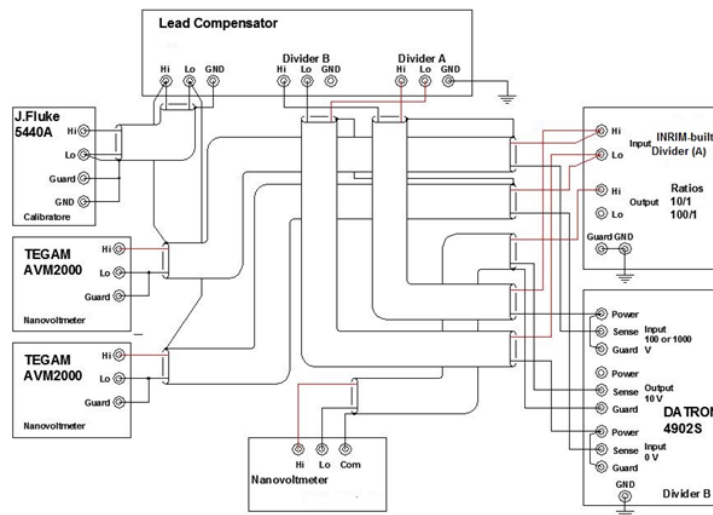

Fig. 10. Electrical scheme of calibration setup of the INRIM standard divider. The measurement procedure requires three nanovoltmeters, the two ones on the left act as null detectors (D_1 and D_3 in the text), while the third (D_2 in the text) measures the unbalance voltage between the two dividers under comparison.

4.2 Uncertainties of the calibration method of the INRIM fixed-ratios divider vs. the INRIM standard divider

In Table 2, the standard uncertainties budgets of the calibration of the 10:1 and 100:1 ratios of the INRIM- fixed-ratios divider with the comparison method vs. the INRIM standard divider, are given.

Table 2.

Standard calibration uncertainties of the 10:1 and 100:1 divider ratios.

10:1 ratio			100:1 ratio		
Uncertainty component	type	1δ ($\times 10^{-8}$)	Uncertainty component	Type	1δ ($\times 10^{-8}$)
standard divider calibration	B	12.5	standard divider calibration	B	14.7
standard divider drift	B	6.0	standard divider drift	B	5.0
Δ_3 nulling	B	2.0	Δ_3 nulling	B	2.0
Δ_1 nulling	B	0.2	Δ_1 nulling	B	negl.
Δ_2 noise	A	2.5	Δ_2 noise	A	2.5
$D_{2\text{resolution and 0}}$	B	2.5	$D_{2\text{resolution and 0}}$	B	2.5
D_2 gain	B	1.0	D_2 gain	B	0.8
D_2 calibration and drift	B	0.2 ⁴	D_2 calibration and drift	B	0.2 ⁴
leakage	B	negl.	leakage	B	negl.
heating	B	2.0	heating	B	2.0
RSS		14.5			16.1

4.3 Comparison results between the two calibration methods.

Fig. 11 shows the calibrations results of the INRIM fixed ratios-divider with the two methods in two years. As the measurements agree, the quick calibration method can be considered reliable. In addition, the divider 10:1 ratio showed a remarkable value stability. Anyway, the long-term ratio stability is not strictly necessary as the divider can be quickly and automatically re-calibrated when necessary.

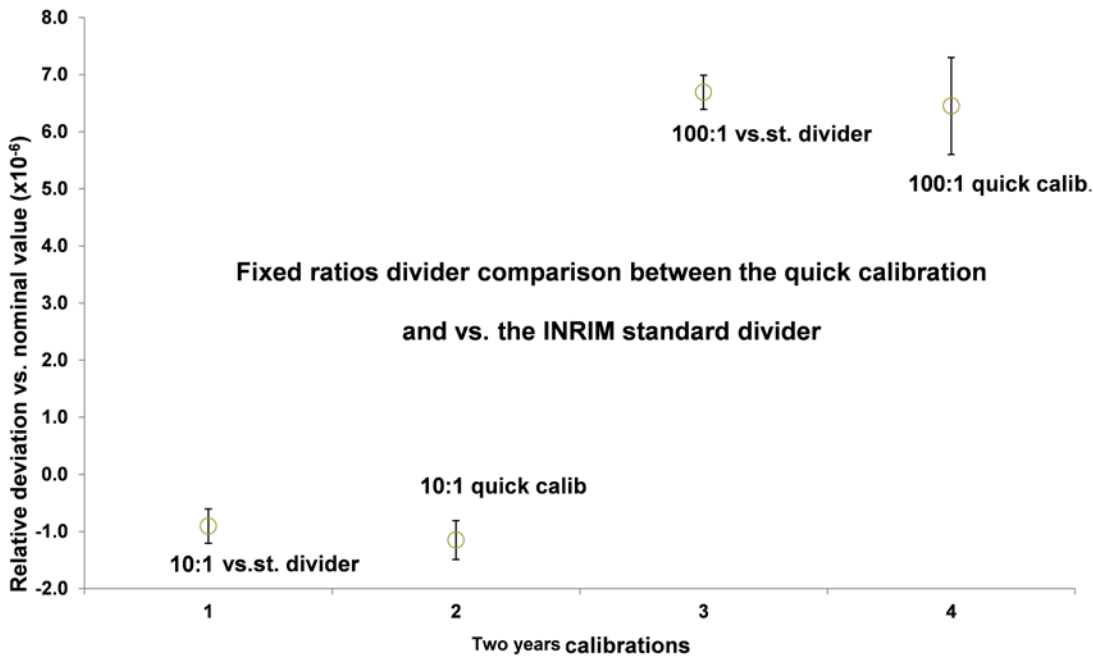

Fig. 11. Calibration values of the 10:1 and 100:1 ratios of the INRIM fixed-ratios divider obtained with the method of comparison with the INRIM standard divider and with the quick calibration method.

⁴ This uncertainty value regards the unbalance voltage (on the order of some μV) to relate to the calibration voltage V .

CONCLUSIONS

As the characterization results of the INRIM-built automated fixed-ratios divider have been satisfactory and its calibration uncertainties **resulted** suitable, it can be employed in an automated setup to calibrate DC voltage generators tracing them to the DC voltage National standard, **being the divider itself also interconnectable to a high precision 10 V standard**. Such calibration process can run automatically without the presence of operators avoiding undesired noises and saving a lot of time with respect to a similar manual process for which several working days **are** necessary. Further aims of this work could be the verification of the short-time stability of the divider ratios to establish their calibration interval and the transfer of the divider concept to secondary electrical laboratories with similar calibration needs and to manufacturers **of** electrical instruments.

ACKNOWLEDGMENT

The authors wish to thank Cristina Cassiago that wrote the software to manage the divider calibration process and for her advice in the elaboration of the paper.

References

- [1] C. Cassiago, G. La Paglia, U. Pogliano, Stability evaluation of high-precision multifunction instruments for traceability transfer, *IEEE Trans. Instrum. Meas.* 49 (6) (2000) 1206–1210.
- [2] Fluke Corporation, 752 A reference divider Instruction Manual, Revision 1, 1984.
- [3] Fluke Corporation, 720 A Kelvin Varley voltage divider instruction Manual, Revision 2, 1974.
- [4] Y. Sakamoto, T. Endo, H. Shao, S. Matsuzawa, Automated dc voltage divider to calibrate voltages up to 1 kV, in: *Prec. El. Measur. Conf. CPEM*, (2000) 363–364.
- [5] Tadashi Endo, Y. Sakamoto, T. Sakuraba, Y. Murayama, H. Yoshida, A. Odawara, Automated voltage divider to calibrate a 10-V output of Zener voltage standard, *IEEE Trans. Instrum. Meas.* 40 (2) (1991) 333–336.
- [6] H. Hirayama ; M. Kobayashi, K. Murakami, T. Kato, 10-kV high-Accuracy dc voltage divider, *IEEE Trans. Instrum. Meas.* 23 (4) (1974) 314–317.
- [7] Yi Li, Miyuru K. Ediriweera, F. S. Emms, A. Lohrasby, Development of precision DC high-voltage dividers, *IEEE Trans. Instrum. Meas.* 60 (7) (2001) 2211–2216.
- [8] R.B.D. Knight; P. Martin, A high voltage divider having an uncertainty of 5 p.p.m. at 100 kV, *IEEE Trans. Instrum. Meas.* 54 (5) (2005) 568–570.

- [9] N. Dragounova, Precision high-voltage dc dividers and their calibration, *IEEE Trans. Instrum. Meas.* 42 (2) (1993) 1911–1915.
- [10] A. Mereva, Ö. Kalenderli, The construction of a dc high voltage precision divider, *Journal of Electrostatics* 67 (5) (2009) 741–745.
- [11] Agilent Technologies, 3458A multimeter - User's Guide, revision: B.01, March 2001.
- [12] A. Sosso ; R. Cerri, Calibration of multimeters as voltage ratio standards, in *Prec. Elec. Conf. CPEM 2000*, Sydney, NSW, (Australia), 2000, pp. 375–376.
- [13] J. I. Gies, Sub-ppm linearity testing of a DMM using a Josephson junction array, *IEEE Trans. Instrum. Meas.*, 40 (2), (1991) 329–332.
- [14] Fluke Corporation, 5700A/5720A Series II Multi-function calibrator Service Manual, Rev. 1, 3/02, June 1996.
- [15] G. Marullo-Reedtz et al., Comparison CCEM-K8 of dc voltage ratio: Results", *IEEE Trans. Instrum. Meas.*, 52 (2), (2003), pp. 419–423.