



ISTITUTO NAZIONALE DI RICERCA METROLOGICA Repository Istituzionale

The factors affecting visual discomfort of dental hygienist

This is the author's accepted version of the contribution published as:

Original

The factors affecting visual discomfort of dental hygienist / Iacomussi, Paola; Carcieri, P.; Rossi, Giuseppe; Migliario, M.. - In: MEASUREMENT. - ISSN 0263-2241. - 98:(2017), pp. 92-102.
[10.1016/j.measurement.2016.11.022]

Availability:

This version is available at: 11696/54509 since: 2017-02-22T15:04:35Z

Publisher:

Elsevier

Published

DOI:10.1016/j.measurement.2016.11.022

Terms of use:

This article is made available under terms and conditions as specified in the corresponding bibliographic description in the repository

Publisher copyright

(Article begins on next page)

Measurement

Elsevier Editorial System(tm) for

Manuscript Draft

Manuscript Number: MEAS-D-16-00460R1

Title: The factors affecting visual discomfort of dental hygienist

Article Type: Research Paper

Keywords: Visual comfort, lighting quality, glare, dental lighting, dental hygienist practice

Corresponding Author: Dr. paola iacomussi,

Corresponding Author's Institution: INRIM

First Author: paola iacomussi

Order of Authors: paola iacomussi; Giuseppe Rossi; paola carceri; mario migliario

Abstract: The objectives of the paper are to analyze the visual behavior and visual discomfort parameters of dental practitioner at work, introducing the "lighting quality" approach in professional lighting using a suitable measurement methodology able to evaluate all relevant photometric and spectral parameters, not only the standard expected, and also the luminance map of the visual field. Spectral investigations are necessary to evaluate the damage potential of the lighting radiation while the luminance map allows the evaluation of sources of visual discomfort and disability. The "quality of lighting" is a new concept not yet considered in professional lighting but already recognized in road lighting standards. The paper provides also suggestions for new measurement methodology and lighting fixture design are provided and, for dental practitioners, recommendations about position and eye protection system to wear to improve visual comfort and minimize musculoskeletal disorders, due to misplaced working position to avoid glare.

Cover letter

This paper is about an interdisciplinary research on the exposition to high light levels during work: the visual behaviour and visual discomfort parameters of dental hygienist at work are analysed on the field with innovative methods usually applied in road lighting to evaluate quality parameter in lighting.

The analysis of Standards is compared with the on field results. At the end the paper suggests new measurement methodologies for evaluating the lighting quality of the fixture and new design approach. To dental practitioners, recommendations about position and eye protection system to improve visual comfort and minimize musculoskeletal disorders, due to misplaced working position to avoid glare are given.

It is to note that the problems arising from exposition to high luminous levels is debated in standards and regulations considering always the point of view of observers (in the case of Dentistry, of the patient and not of the operator) or the maximum exposition allowed for long period of time. Limiting values suggested in European regulation [1] on light exposure and blue light hazard are only for direct observation of the source for a defined period of time (usually higher than 10 second). But people working in sanitary fields with Operating lights, like Dentistry, obviously don't look directly in the luminous source, but are exposed to very high levels for long period of time, with (and this is the essence of the paper) very bright points of specular reflection of the source in the observation field.

Considering the irradiance values in the area where the specular reflection of the source arrives, those are comparable to that of a source: the reflections in the operator field of view are all small sources providing glare and diseases (eyestrains, headache...) to the operator, including musculoskeletal disorders. However, there are some circumstances in which the emissions reach potentially harmful levels, resulting in damage to the visual mechanism, particularly the components of eyeball, eg cornea, lens capsule and the retina. The type of damage depends on the wavelength of the optical radiation.

This paper is a first study on the visual comfort and visual behaviour on the field, and presents the measured values, including some easy solutions for practitioner to avoid the principal disturbs coming from the high lighting levels.

The research team is composed by INRIM Dept. of Optics, INRIM is the Italian

Metrologic Institute and is specialized in measurement procedures and on field visual analysis, and the, University of Eastern Piedmont "Amedeo Avogadro, Dept. of Health Sciences.

[1] DIRECTIVE 2006/25/EC OF THE EUROPEAN PARLIAMENT AND OF THE COUNCIL on the minimum health and safety requirements regarding the exposure of workers to risks arising from physical agents (artificial optical radiation) (19th individual Directive within the meaning of Article 16(1) of Directive 89/391/EEC)

Highlights

The factors affecting visual discomfort of dental hygienist

- Interdisciplinary research with innovative on field measurement methods
- Standards requirements are compared with working conditions implementations
- Protective equipment interferes with lighting and deteriorates visual conditions
- One working position was identify for increasing visual quality of practitioners
- Standard and lighting fixture design should incorporate the paper suggestions

Cover letter

The authors acknowledge the reviewer for the comments on the paper and thank for the fruitful suggestions that really improved the readability and understanding of the paper.

All comments have been incorporated:

- Typos mistakes corrected, as well the mistakes on the number of samples on Ra (we apologise for this).
- References to the different standards have been improved, clarifying the standard requirements (section 2.2 and 3.3).
- New references and statements have been inserted about the lighting quality (section 2.1), visual performances and ergonomics (section 2.2) including description harmonization with the concept of contrast, and glare in interior lighting and displays (section 3.3).
- New drawings have been inserted in section 2.2 about practitioner position as well in section 3.3 useful for the final remarks about practitioner good position.
- Layout of all figures about on field measurements has been changed according to the reviewer suggestion.
- Where necessary sentences have been improved to increase the understanding of the paper.
- The ΔE values have been calculated for the selected samples and the results are included in the text. The application of ΔE method allows inserting new statements about the different approaches of Colour rendering and colour differences methods.
- Statements about comparison with Directive 2006/25/EC and radiance of the light and magnification viewing system influences have been included in the text.

Authors would like just to remark that it was not possible to fully incorporate the suggestions about the definition of the two practitioner positions (“12 o’clock” and “9 o’clock”) as right and bad because, unfortunately, some surgeries can be performed only in the position (“9 o’clock”) that the research highlighted as the worst. The reviewer comment has been incorporated adding a new drawing of the two positions and a statement that practitioner in the “9 o’clock” position is more subjected to MSD and visual fatigue, while “12 o’clock” position increase the quality of lighting and visual behaviour.

Authors appreciated the reviewer for completely understanding the approach of the research, and hope that the revised version fully satisfies the reviewer suggestions.

The version submitted includes the track changes in order to highlights all changes.

Best regards

Paola Iacomussi, corresponding author.

The factors affecting visual discomfort of dental hygienist

Corresponding author:

Paola Iacomussi, Strada delle Cacce 91, 10135 Torino, Italy;

p.iacomussi@inrim.it, tel +39 011 3919228

Authors

P. Iacomussi¹, P. Carcieri², G. Rossi¹, M. Migliario²

¹Istituto Nazionale di Ricerca Metrologica, Dept. Optics, INRIM, Torino, Italy

²Degree Course in Dental Hygiene, Dept. of Health Sciences, University of Eastern Piedmont "Amedeo Avogadro", Alessandria-Vercelli-Novara, Italy.

KEYWORDS

Visual comfort, lighting quality, glare, dental lighting, dental hygienist practice

CCT: Correlated Colour Temperature

C: Intrinsic Contrast

FOV: Field Of View

LED: Light Emitting Diode

MSD: Musculoskeletal Disorders

UGR: Unified Glare Rating

VP: Visual Performance

ABSTRACT

The objectives of the paper are to analyze the visual behavior and visual discomfort parameters of dental practitioner at work, introducing the “lighting quality” approach in professional lighting using a suitable measurement methodology able to evaluate all relevant photometric and spectral parameters, not only the standard expected, and also the luminance map of the visual field. Spectral investigations are necessary to evaluate the damage potential of the lighting radiation while the luminance map allows the evaluation of sources of visual discomfort and disability. The “quality of lighting” is a new concept not yet considered in professional lighting but already recognized in road lighting standards. The paper provides also suggestions for new measurement methodology and lighting fixture design are provided and, for dental practitioners, recommendations about position and eye protection system to wear to improve visual comfort and minimize [MSD](#), due to misplaced working position to avoid glare.

1. Introduction

European standard “EN 12464-01:2011 Lighting of work place – Indoor work places”(CEN 2011), represents the reference standard for lighting of indoor work areas. It specifies requirements (quantitative values of main lighting quantities) and suggestions to ensure visual comfort, accomplishment of visual task and safety of people working in indoor areas.

Visual tasks can be very different depending on the job required, therefore, the European standard provides dedicated tables for 53 different work tasks of which 14 for Healthcare Premises. Among these, Dental surgeries are included. About Dentists workplace lighting, the standard refers also to “EN ISO 9680:[2007](#) Dentistry Operating Lights ”standard,

where additional quantitative requirements are considered such as illuminance levels¹, and Colour Rendering Index². However, the ISO standard is focused on photometric, electrical and mechanical performances of operating lights. No considerations or prescriptions about lighting conditions or practitioner visual behaviour are given.

During practice, dental practitioners are exposed to very high luminance levels³, for long time, whilst performing crucial visual task, and can therefore experience visual discomfort. As regards visual discomfort, there is no widely accepted definition: usually the presence of visual discomfort is characterized by symptoms (difficulty in performing a visual task, annoyance, stress, and even physical effects such as headaches, pains, sore, itching, watering eyes) clearly recognizable and associated with a source of the discomfort.

The main parameters able to break visual comfort are generally recognised as (EN12464:01-2011, Rossi et al 2013):

- Presence of glare from lighting sources or surfaces, especially overhead glare;
- Too low or too high illuminance and luminance levels, related to the visual task;
- Too low or too high luminance uniformities (depending on the level of adaptation).

In this research, the available European Standard for dental practitioner lighting are analysed and a dental workplace unit is characterized for the relevant photometric and

¹ Illuminance is the amount of light on the area of work, 845-01-38 in CIE 17.4:1987 is measured in [lx]

² Colour Rendering Index Ra is the degree of difference in perceiving reference colours, Ra is a number (1-100) measuring the difference in the colour of 14 reference objects, as rendered by the source used in dentistry lighting and by a source assumed as a reference: 100 means no difference between the rendering capabilities of the two sources. Values lower than 75 identify very strong differences, higher than 95 identify very small differences. The value Ra is obtained as mean value of the all values (Ri) of the 14 reference samples (one Ri for each coloured sample), the most relevant samples for this research are: sample 9 (Ri9) representative of strong red, sample 10 (Ri10) yellow and sample 13 (Ri13) representative of the human skin.845-02-61 in CIE 17.4:1987

³ Luminance (845-02-35 in CIE 17.4 1987) is the quantity perceived by the human eye, luminance is the luminous flux reaching the observer's eye, coming from a defined surface (real or imaginary that subtend a solid angle) from a defined direction (measured in [cd/m²])

visual parameters, in order to provide indications useful for a new approach to evaluate visual comfort (Rossi et al, 2010, 2013a).

It must be clear that the visual task of dental practitioner is very critical: very small details to focus on, crucial colour perception and risk of damaging the patient in case of mistake. Heavy and crucial visual task usually requires high illuminance levels as stated in both standards EN 12464-01 and ISO 9680, but high illuminance levels expose the operator to fatigue and visual discomfort.

This research considers the visual conditions of dental practitioners, especially focussed on dental hygienists although the indications are still valid for every dental practitioner. The paper highlights the main factors inducing visual discomfort during work, provides precautions for practitioner lighting set up and sets first quality criteria for dentistry lighting. Because “Lighting of Quality” doesn’t necessarily means “Lighting of Quantity”.

2. Materials and Methods

The available normative documents about lighting for Dentistry (EN 12464-01:2011 and ISO 9680) were analysed. Thereafter, a typical dental hygienist work-place, equipped with dental lighting fixture standard ISO 9680 compliant, was characterised in terms of relevant photometric quantities, and visual discomfort parameters using a dedicated INRIM methodology as described by Rossi et al 2013 and Iacomussi et al 2005, as standardised methodology was not available. To evaluate parameters of visual discomfort a luminance map of the practitioner field of view in different practitioner positions, was acquired using a luminance calibrated Charge Couple Device (CCD) detector (Rossi 1999, Iacomussi 2005).

2.1. Reference standards analysis

European standard “EN 12464-01:2011 Lighting of Work Place – Indoor Work Places”, specifies the requirements needed to ensure visual comfort and to perform visual task and safety in different working places, including Healthcare Premises for Dentist (table 5.48 of EN 12464-01:2011).

The European Standard considers four areas with different lighting parameters requirements: the room general lighting, the lighting at the patient, the operating cavity lighting and the lighting for teeth matching. The relevant parameters are (Table1):

- Maintained illuminance (E_m), the quantity of light incident on a surface (definition 845-01-38 in CIE 17.4:1987);
- Unified Glare Rating (UGR), a number identifying the amount of discomfort glare suffered by a subject: the higher the value, the higher the glare (CIE 117:1995, Rossi 1999);
- U_0 , the minimum illuminance uniformity, that identify the ratio between the maximum and the minimum value of Illuminance in the area of interest;
- Ra, the minimum value of Colour Rendering Index (definition 845-02-61 in CIE 17.4:1987).

Table 1: Reference Values of lighting parameters as request in EN 12464-01:2011 in table 5.48.

Reference	Area of interest	Maintened Illuminance [lx]	UGR _L	U_0	Ra	Requirements
5.48.1	General lighting	500	19	0,6	90	Glare free for the patient
5.48.2	At the patient	1000	-	0,7	90	
5.48.3	Operating cavity	-	-	-	-	Rif. EN ISO 9680
5.48.4	White teeth matching	-	-	-	-	Rif. EN ISO 9680

It is to note that glare requirements are provided only for premises general lighting or for the patient, while for the practitioner area (i.e. operating field) no UGR value is provided:

nevertheless practitioner is subjected to high glare levels. Indeed the practitioner Field Of View (FOV) is the patient mouth: no lighting fixture is in the FOV, however it doesn't means that the practitioner is free from glare or he doesn't see (in his field of view) glaring sources.

The most important area to be lighted is, obviously, the patient's mouth (Operating Cavity), where the visual task is. For Operating Cavity and teeth matching, "EN 12464-01:2011" doesn't specify reference lighting parameters values and refers to "EN ISO 9680:2007".

However ISO 9680:2007 is a technical standard about dental lighting fixtures: it specifies requirements and test methods for electrical, mechanical and photometrical performances of lamps designed to illuminate the oral cavity of patients. ISO 9680:2007 is not a standard about lighting, but about performance of lighting fixtures, it does not provide any useful information about the lighting nor methods or attentions to be paid to reach good quality of technical lighting.

Instead EN 12464-01:2011 is a standard about lighting: it suggests, as a good practice common to all workplaces, lighting design criteria to ensure the proper visual comfort in terms of luminances distribution, intrinsic contrast C (the relative difference in luminance between an object and its background) and several other parameters that fit well for interior lighting, but not for technical lighting. Dentistry lighting is a very technical lighting and common lighting design criteria can hardly be applied.

Obviously both standards do not adopt a "lighting quality" approach and refer to quantitative parameters for performances that don't applied to dental lighting or situations with workers exposed to high intensity lights for long time a day.

Technical lighting requires the definition of some parameters values, the most important parameter is illuminance: it necessary to provide enough light to achieve defined visual

performances. Indeed being able to execute a task does not assure the visual comfort and safety of the practitioner nor the best lighting conditions for task execution. It is necessary to define new parameters focused to improve the quality of lighting: no accepted definition for lighting quality is available. The quality of light is a subjective experience, depending on several aspects related to the subject, usually is judged according to comfort, activity and level of performances needed.

An approach based on quality parameters is already applied in interior lighting (IES 2009) and road lighting (EN 13201-4) with measurand related to parameters able to describe human interaction with light. These parameters are mostly related to spectral distribution of light (Ra and CCT), intensity distribution in the field of view (uniformity and glare), but it is not possible to define a single parameter to assure "lighting quality" because lighting scenario and users must be considered too. Several lighting quality index have been proposed, some of them are related only to the lighting source properties (Jwo-Huei 2014), others are also based on Environmental Psychology like the VBE Index (Visual, Biological, Emotional Index) (Laike 2010) but is of difficult application in lighting standards. However EN12464-01:2011 already considers some quantitative parameters related to visual comfort, but not in sections dedicated to dentistry and other technical lighting: to introduce a quality metric approach for dentistry lighting it is absolutely necessary a deep analysis of the dental practitioner visual condition, including field measurements of normative and qualitative parameters.

2.2. Analysis of the visual task of a dental hygienist practitioner

The visual system assignment is to extract information from the environment, its performance, VP, is measured by the speed and accuracy with which a particular task is performed (CIE 145:2002). Usually the visual task is the recognition of the orientation of Landolt rings in different visual conditions. Age, visual conditions, contrast and illuminance

levels influence the visual performances. If the procedure of extracting information is hard and difficult, possible annoyance symptoms arrive (like fatigue, eyestrain headaches, pains, sore...).

Figuring the visual system as a process of evaluation of a “signal to noise” ratio, the signal is the visual task, while the noise is represented by all other visual information coming inside the eye (due to internal eye scattering, or coming from in or out of sight sources) (Rossi et al 2013b). When the “signal to noise” ratio is reduced, is hard and difficult to extract information, usually this happens when C is too low. Low values of C arrives when the difference in luminance between target and background is too little or when some disturbing radiation coming from external glaring sources, in dentistry lighting are the specular reflections, enters the observer eyes. In presence of glare a veiling disk of L_v luminance arises due to the internal eye scattering and term L_v is added to the C denominator: this approach is typical of road lighting calculations (EN 13201-3).

The best value for C is related to the difficulty of the visual task, dental practitioner visual task is very critical: the practitioner is exposed to very high luminance levels, in some cases, for long time while doing heavy visual task with very small details, crucial colour perception and high risk of damaging the patient in case of mistake. Because the lighting set up cannot be changed (in term of intensity, spectral and spatial distribution) practitioners adopt several mechanisms to optimize the C value: the most common approach is to find a geometrical position allowing a reduction of the “noise” signal. Usually the observer displace the head in a position or closer to task to increase its size (decreasing the background size), or to avoid the most disturbing directions of observation, putting the source of the noise signal out of the FOV.

The work place (treatment area) of a dental practitioner is: the dental unit and chair, the dental lighting fixture and the clinician’s chair. The dental lighting fixture produces the maximum illuminance in the patient’s oral cavity. Several factors affect the relative position

of patient and clinician, but the most used patient position is supine. In the supine position the patient's mouth is about at the height of the seated clinician's elbow and at about 40 cm distance from the clinician's eyes; when treating the maxillary teeth the maxilla should be perpendicular to the floor, when treating the mandibular teeth the mandible should be parallel to the floor; always the headrest should be adjusted to allow maximum visibility.

To identify the clinician chair position is usual to assimilate the patient's face to a clock (Figure 1): the nose identify the 12 o'clock direction, while the chin the 6 o'clock direction.

The right-handed clinicians work predominantly with the chair in the position from 8 o'clock to 1 o'clock, the left-handed clinician between 11 o'clock and 4 o'clock.

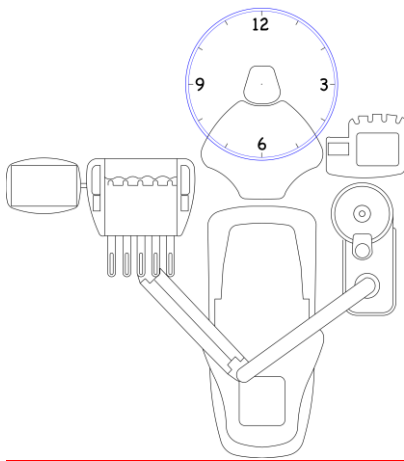

Figure 1: The reference system, assimilating the patient's face to a clock

A variety of patient and operator positions are used during dental hygiene treatments but patient position should always allow the operator to perform intraoral procedures without increasing Repetitive Strain Injuries.

Considering only the visual task of a dental hygienist, the centre of the FOV is highly illuminated: about 40 times higher than a typical office desk, and just outside the operating field, the illuminance sharply drop off, unfortunately in some cases a sort of spot light effect arrives, especially in the case of LED lighting fixtures (that will be considered in the next stage of this research).

The simplest reaction to a high level of visual difficulty is to bring the task closer to increase its visual size: some practitioner move the head closer to the patient adopting wrong working positions. As the task brought closer, the accommodation mechanism of the eye adjusts to keep the retinal image in focus, an adjustment that might make it operate close to its limits. This adjustment can lead directly to fatigue of the eye muscles, and indirectly to fatigue of other muscles because the observer adopts an unusual posture that can produce MSD, especially if the incorrect posture is maintained for long period of time. The mechanism adopted by the observer can be monitored using eye tracker systems.

Some practitioners prefer to work with magnification viewing systems: in this case the task brought closer and, depending on the system used, the luminance of the operating field is lowered (because the optical diaphragm of the magnification system) as well as the angular extension of the field of view. The influences of magnification viewing systems will be analyzed in the next stage of this research.

The field of view of the practitioner during intra oral activity can be different, depending on the working position, but always includes the patient face as well a little portion of the surrounding, the visual task is performed in a small region (patient's mouth), fully focused in the fovea. Several objects, with different colours and reflectance, are inside the operating cavity where the lighting fixture produces the highest level of illumination

(standard EN 12464 – 01 [refers to ISO 9680 where lighting fixture has to provide a maximum illuminance](#) greater than 20000 lx):

- [Patient](#) teeth and tissues, with different shades of red and white and with mostly a diffuse behaviour in reflecting light in space and back to the hygienist;
- [Instruments](#), manual or mechanical, all with metallic operative ends but different shapes, size, colours, materials, and different behaviours in reflecting light in space (the most interesting for this research is about specular reflection);

- Gloves of different colours, with a diffuse behaviour in reflection, covering the hands of the practitioner.

All materials reflect a portion of the incident light in space; with diffuse behaviour the incident light is reflected quite uniformly in space (matt surfaces); with specular behaviour the light is reflected mainly in the specular direction (mirrors, glossy/polished surfaces).

Biological tissues behave as diffuse materials, with a small specular peak related to the polishing level and wet condition, while metallic instruments ends are usually polished and behave as mirror surfaces: it is obvious that instruments with metal knurled handle reflect higher in the specular region than satin finished one and those coated with plastic anti-slip material reflect least of all.

2.3. On field analysis

The following lighting characteristics were evaluated on a dental unit (ISO 9680:2007 compliant) used by dental hygienist students at the Degree Course in Dental Hygiene, of Università del Piemonte Orientale “A. Avogadro”, Dental Clinic of Ospedale Maggiore della Carità di Novara, Italia.

- Maximum illuminance on an horizontal plane at 0,7 m distance from the lamps photometric centre, as requested in EN ISO 9680, with the lamp parallel to the measurement plane;
- Illuminance values on an horizontal plane, representative of the patient, with the dental lighting arranged (distance and tilting) by a dental hygienist, not visually impaired, to fulfil his visual requirement for operating on a patient (working position in the following);

- Spectral distribution of the lighting source in the working position, the measured values were used to calculate Correlated Colour Temperature⁴ (CCT), R_a and R_i values, and colour differences using the CIELAB ΔE 1976 formula⁵;
- Luminance map acquired positioning the CCD camera detector in the two dental hygienist working positions of Figure 1 (9 hours and 12 hours).

The strength key of the measurement methodology is the analysis of the practitioner visual behavior with the lamp in working position. This is done acquiring a luminance map of the visual field; this methodology is able to overcome the limitations of normative requests allowing the evaluation of the visual conditions of the dental hygienist during work.

The measurement methodology was developed by INRIM and is based on CCD camera detector conveniently calibrated (Fiorentin et al 2005). CCD camera detectors are very useful in lighting engineering measurements because allow the evaluation of luminance maps and of qualitative performance parameters of a lighting system. INRIM usually applies such methodologies to evaluate conditions of vision and quality parameters for interior lighting and road lighting (Iacomussi 2005, Rossi 1999)

⁴ CCT is the temperature measured in Kelvin [K], of the black body with the same perceived colour of the source, definition 845-03-50 in CIE17.4:1987). CCT is an indication of the perceived colour of the light: usually temperatures less than 4000K are associated with “warm lights”, while temperatures above 5000K with “cold lights”

⁵ ΔE formula allows expressing the difference between two colours as metric distance between the two points representative of the colours in the CIELAB color space. 1,6 ΔE is usually referred as just perceivable colour difference.

In this study a Nikon D3S CCD camera, characterized and calibrated as stated in (Fiorentin et al 2005) was used to acquire the luminance maps, while illuminance was acquired with a Delta Ohm HD2102 cosine corrected illuminance meter, and spectral distribution with a spectroradiometer Instrument System MAS40.

3. Results and Discussion

3.1. Illuminance measurements

In Table 2 the mean values of illuminance are shown.

Table 2. Comparison of measured and normative illuminance values on a dental hygienist workstation

Type of area from UNI EN12464	Normative requirement	Measured value (source in working condition)	Measured value (source in normative)
	Maintained illuminance	Mean illuminance	Max illuminance
	E_{min} [lx]	E_{m} [lx]	E_{M} [lx]
General lighting	500	900	-
At the patient	1000	700	-
Operating cavity	≥ 20000	16300 (max value)	25500

The values representative of general lighting were acquired on several measurement points on the furniture inside the room where the dental hygienist workstation stands, with the dental lighting fixture switched off and only the general lighting on. The illuminance value on the patient is the mean value of different acquisitions on the patient face with the dental lighting fixture in working position. With the lamp in the same working position, and substituting the patient face with a reference horizontal plane, the illuminance map of Figure 2 was acquired the top of the figure is “12 hours” following the reference system of Figure 1. The uncertainty on illuminance values is $\pm 5\%$.

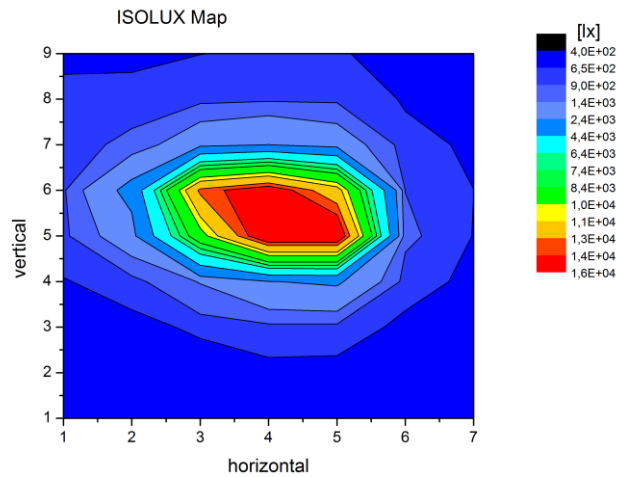

Figure 2. Isolux map on an horizontal plane positioned at the patient face position, top of the picture is “12 hours” of Figure 1, with the dental lighting fixture in working position, distance between point of measurement 4 cm.

3.2. Spectral distribution measurements

The spectral distribution of the dental lighting source was acquired, with the dental light in the working position (as stated before), in two points on a plane representative of the centre of the patient mouth and of the lower border of patient mouth. The spectral distribution of the light is shown in Figure 3, while the calculated values of CCT, Ra and Ri for selected samples in Table 3.

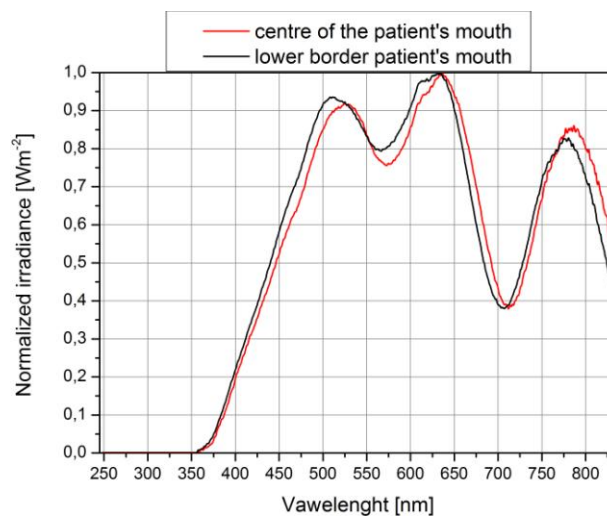

Figure 3. Spectral distribution of dental lighting source measured in two different positions around the operating cavity.

Table 3. CCT, Ra Index, special Ri and ΔE calculated values for selected samples.

Point of measurement in the lighted field	CCT [K]	Ra Index	Ri 9 (red)	ΔE red sample	Ri 10 (yellow)	ΔE yellow sample	Ri 13 (human complexion)	ΔE human complexion sample
At the centre	4550	95	92	2	90	2	94	3
Lower border of the patient's mouth	4460	95	85		93		94	

The Ra, as aforesaid, is a number measuring in the mean how a source is able to render the colour of 16 reference coloured samples as a reference source do, for this study the most interesting coloured samples are: 9 (strong red), 10 (yellow) and 13 (human skin).

Figure 3 shows the difference in the spectral distribution of the light on a horizontal surface, representative of the operating cavity. This difference can be ascribed to the reflector inside the lighting fixture. Is by way of the reflector that the light of the lamp is focused on the operating cavity and the spatial distribution of the luminous intensity achieved.

The differences in the spectral distribution of the incoming light in the operating field generate small differences in the perceived colour of the objects in the lighted field (Table 3, ΔE values). The calculated Ra value is the same on both measurement positions on the operating field, but the single Ri values are different (especially for the red colour, sample 9, strong red): this clearly demonstrate the limitations of using mean values to describe the colour rendering capabilities of a lighting source. In this case the same red is perceived in the two different positions in the operating cavity, because colour difference ΔE in CIELAB colour space is 2 ΔE , but the colour rendering capabilities of the source are very different with variations of Ri between the two points of 7 Ri units. Considering the others colours (yellow 11, and Caucasian skin 13) the different physical meaning of Ri and ΔE methods is stressed.

3.3. Luminance map measurements

A luminance map is an image in false colour representative of the field of view of an observer: every colour is associated to a different luminance value. Knowing the luminance of the lighted scene, allows the evaluation of parameters more related to the visual perception of observers and to the quality of a lighting installation. In fact the performance of a lighting installation, (i.e. capability of a lighting installation to assure the execution of a visual task, safety and visual comfort) is related to the ambient luminance and not only to illuminance provided (rather than suggested in the standard EN12464 – 01:2011).

A luminance map is related to the visual field of an observer and must be acquired in the same position and viewing direction of the observer: in our research the observer is a dental hygienist at work. As stated before, the dental hygienist usually stands beside the patient in two different positions, “9 o’clock” and “12 o’clock” ([Figure 1](#)) with the viewing direction towards the patient’s mouth. Therefore the CCD camera detector was positioned in both dental hygienist working positions in order to acquire the luminance map of the field of view of the practitioner.

It is to note that dental practitioners usually wear eye protection equipment, these equipment are usually plastic shields, of different sizes and shapes. The refraction index of plastics (i.e. polycarbonate) is higher than that of the air, so at the boundary between plastic and air, if [light hits](#) the device, about the 4% (depending on the angle of incidence) [of](#) the incident light is reflected specularly [by](#) the first surface. This specular reflection produces an image of the lighting fixture in the field of view of the hygienist, depending on the relative geometrical position between dental hygienist and lighting fixture. In order to take in account of this effect, the luminance maps have been acquired with and without, in front of the camera, a typical dental hygienist protective shield, at different degrees of wear, in fact the degree of wear influences a lot the visual conditions of the practitioner.

The measurement conditions and relative position of the CCD luminancemeter are summarized in Table 4 with reference to the Figure numbers.

Table 4. Measurement conditions and relative position of the CCD luminancemeter

Luminance Map	Measurement conditions	
	CCD luminancemeter position	Protective shield
Figure 3	9 hours	without shield
Figure 4	9 hours	brand new protective shield
Figure 5	9 hours	very wreckled shield
Figure 6	12 hours	brand new shield

From the luminance maps is clear that, depending on the working position (9 o'clock and 12 o'clock), the head of the practitioner is in two different geometrical positions respect the illuminating axis of the lighting fixture: in the position at "9 o'clock" the head intercept the direct light rays of the lighting fixture, while this does not arrive in position "12 o'clock".

The luminance maps show high contrast zones that produce glare at the eyes of practitioner.

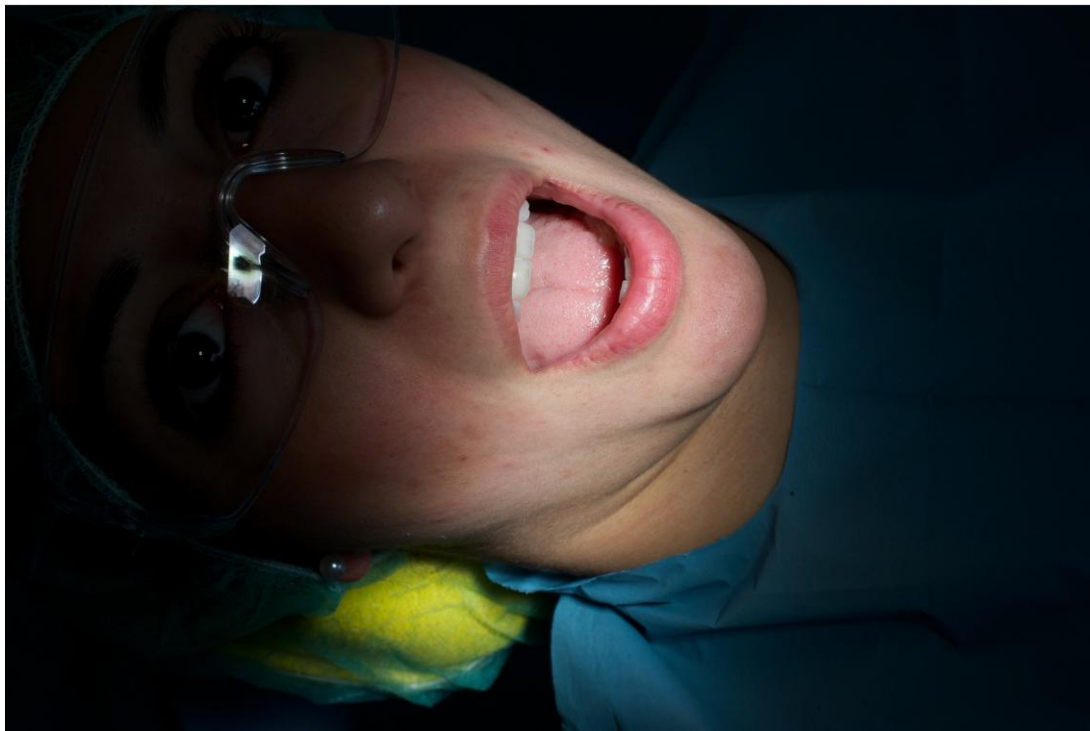
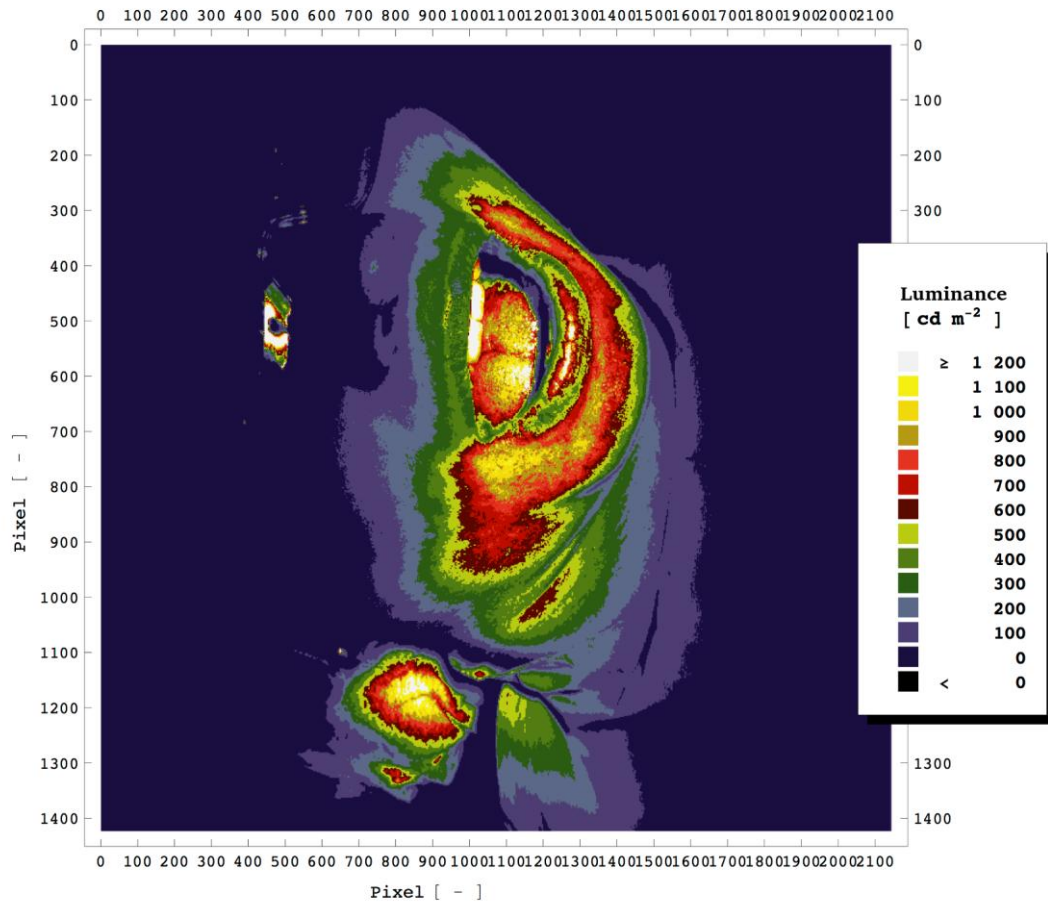

Figure 4. Dental Hygienist position “9 o'clock” luminance map. Ideal condition without protective shield

Glare affects negatively the visual capabilities and comfort of observers, reduces the contrast and, consequently, the ability to perceive and recognize details and objects and causes discomfort or an alteration of object visibility impairing the vision (CIE 147:2002). This alteration is mainly due to the imperfect transparency of human eye elements, the light inside the eye is scattered creating a veil, called “veiling luminance”. This is a well-known concept in road lighting (i.e. at night from oncoming headlights or during the day from the sun when entering in a tunnel, Adrian 1993), [in interior lighting \(EN12464-01:2011\) with UGR limitations, the problem is also well known for displays \(ISO9241-305\) and display in cockpit \(MIL-HDBK-87213A:2005\)](#). Among discomfort symptoms it is to note stress, difficulty of concentration, decrease in performance, eye-strain, headache... Discomfort glare is typical of indoor lighting (CIE 117:1995) when high luminance or difference in luminance arrives, or even strong specular reflection of lighting sources in the visual field of view.

The use of eye protective devices increase the glare when the practitioner is at “9 o'clock” position (i.e. Figure 5) due to the direct reflection of lighting fixture on the shield, but not only: this glaring image force the dental hygienist to assume bad musculoskeletal positions causing MSD to avoid that this strong reflection falls in the operating field of view.

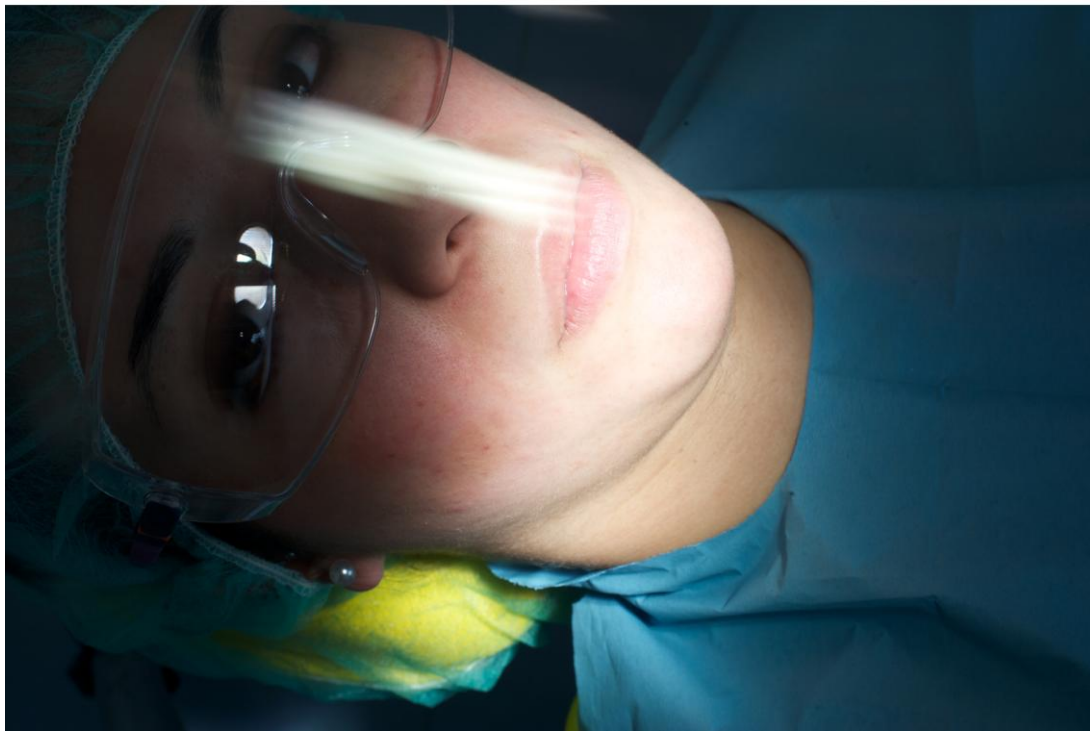
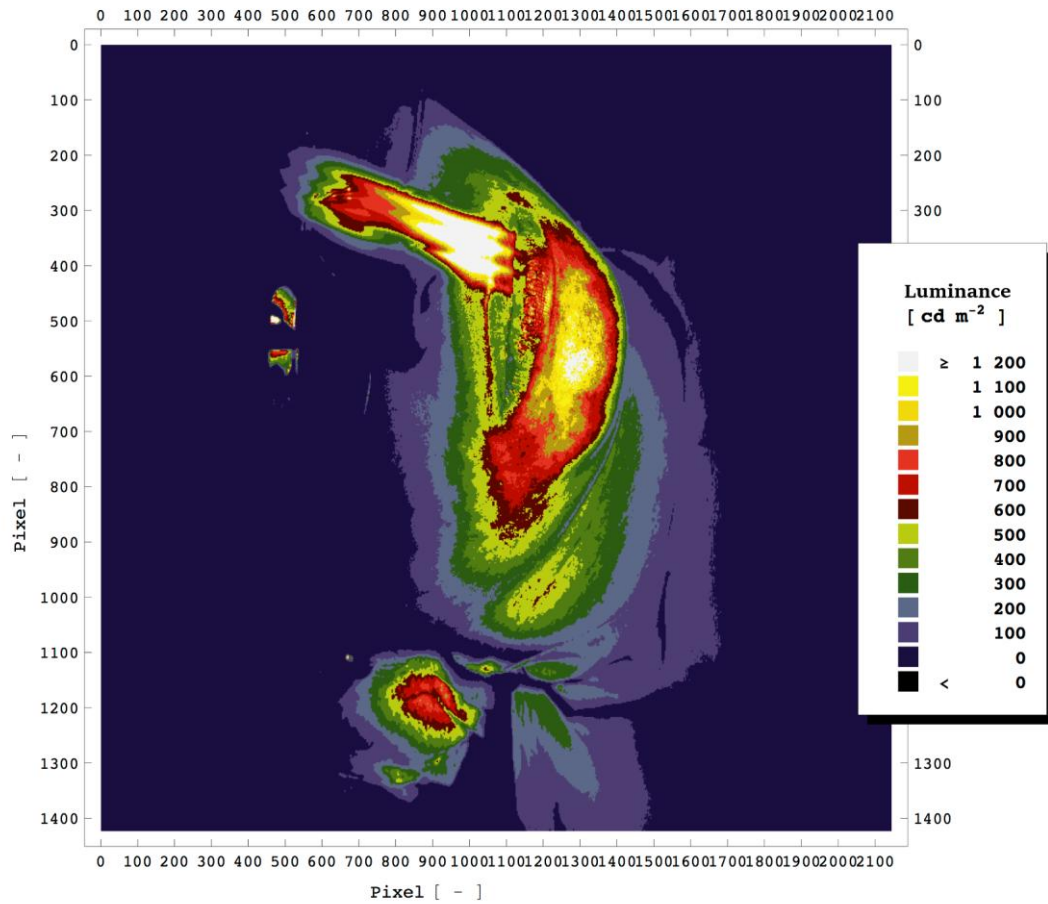

Figure 5. Dental Hygienist position “9 o’clock”luminance map, brand new protective shield. Strong specular reflection in the visual field.

As it is also shown in Figure 5, the luminance of the operating field is very high, higher than 1000 cd/m^2 and higher than 1200 cd/m^2 for the lighting specular reflection image, this means that the practitioner is exposed for long time without break (a typical dental hygienist work like scaling and root planning is at least 1 hour long) to a luminance higher than the typical luminance in office. This very bright area can be compared to a luminous source and considering the time spent during work the limitation for safety in expressed in seconds considered in EU regulation (DIRECTIVE 2006/25/EC) are no more valid. As additional reference, it to say that in office the mean luminance of a display is between 50 and 300 cd/m^2 , usually people working at display for several hours have several breaks during at least four time less than for dental hygienist. Regarding the regulations about the emitted radiance in the different spectral regions (UV; VIS; IR) of the lighting source, ISO 9680 requirements apply and justify the limitation of blue part of the spectrum as well of IR (to avoid damages to biological tissues due to temperature increase) shown in Figure 3. If the practitioner wears magnification viewing system the opposite effect of focus properties and luminous flux limitation of diaphragm of the magnification system arrive and need to be quantified in the second step of this research.

In Figure 6 the same on field evaluations are performed with a protective shield very damaged: the image is completely blurred and a veiling luminance is overexposed to the field of view.

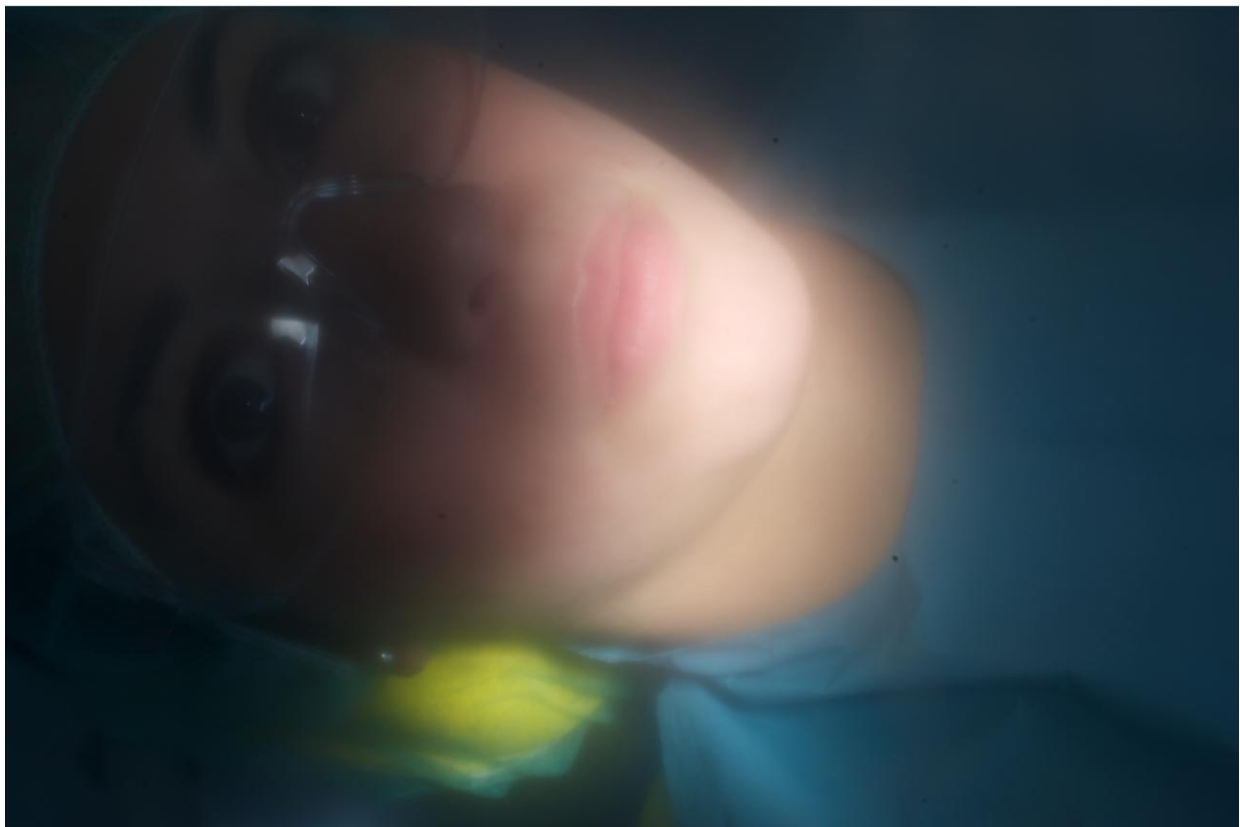
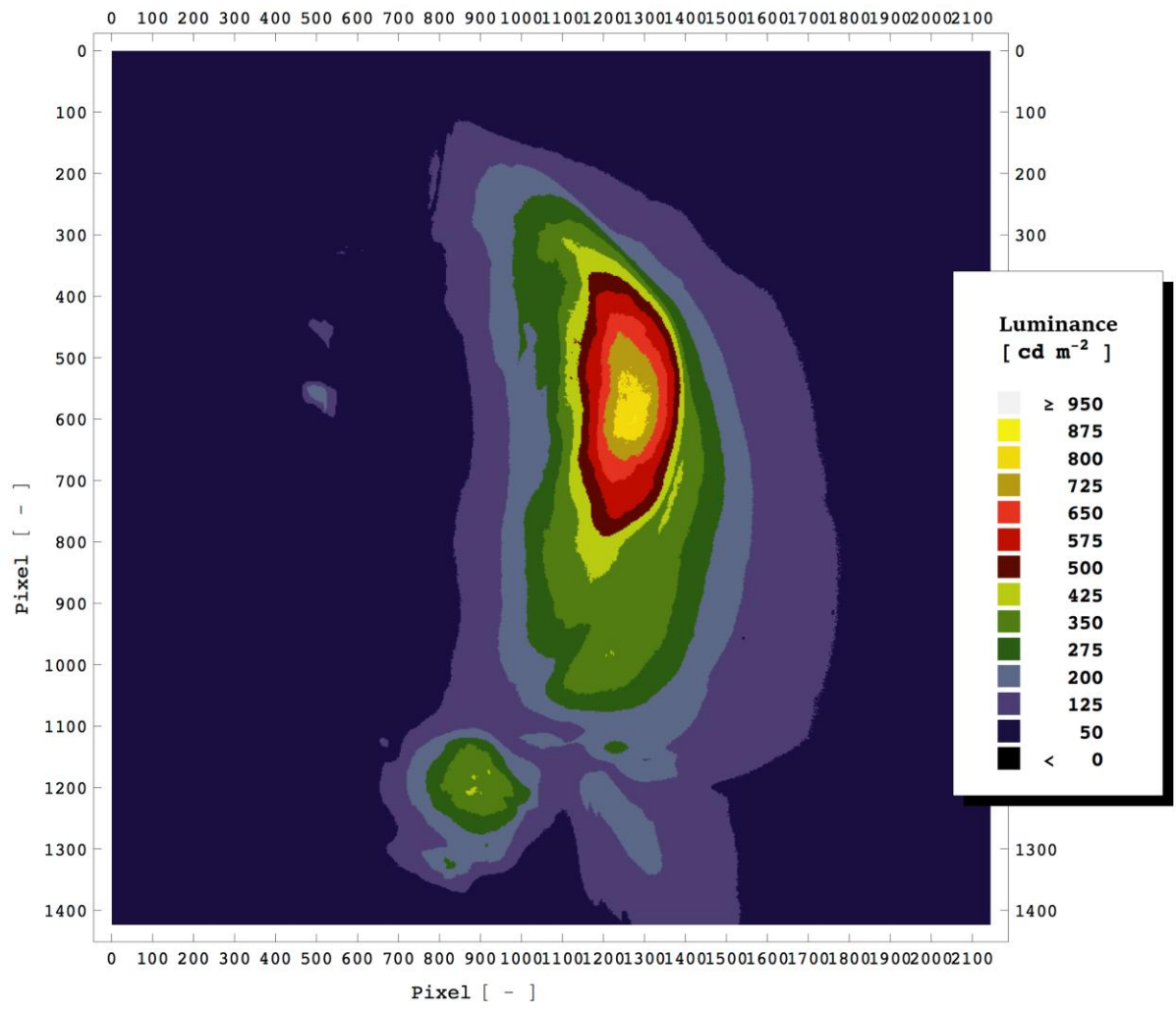

Figure 6. Dental Hygienist position “9 o’clock” luminance map, very wrecked protective shield. The vision is impaired.

Figure 6 highlights the influences of the practitioners visual conditions due to

In Figure 7 the same on field evaluations are performed with a new protective shield as in Figure 4, but with the practitioner in the “12 o’clock position”: the luminance is very high but no specular reflections are on the field. The head and the protective shield of the practitioner do not intercept the light path from the luminaires toward the patient. It is clear that in the “12 o’clock” position no glaring sources are on the practitioner FOV and this position should to be used whenever possible in order to avoid MSD due to practitioner misplacement and visual discomfort and fatigue because glare from specular reflections in the FOV. There is a strong increase of the lighting quality and of visual comfort for practitioners with the simple action of preferring the “12 o’clock” position. Figure 8 is a final drawing of the two most used practitioner positions around the patients, it is to note that the same conclusions about glare apply for left handed practitioners working in “3 o’clock” position (Figure 1) around the patient.

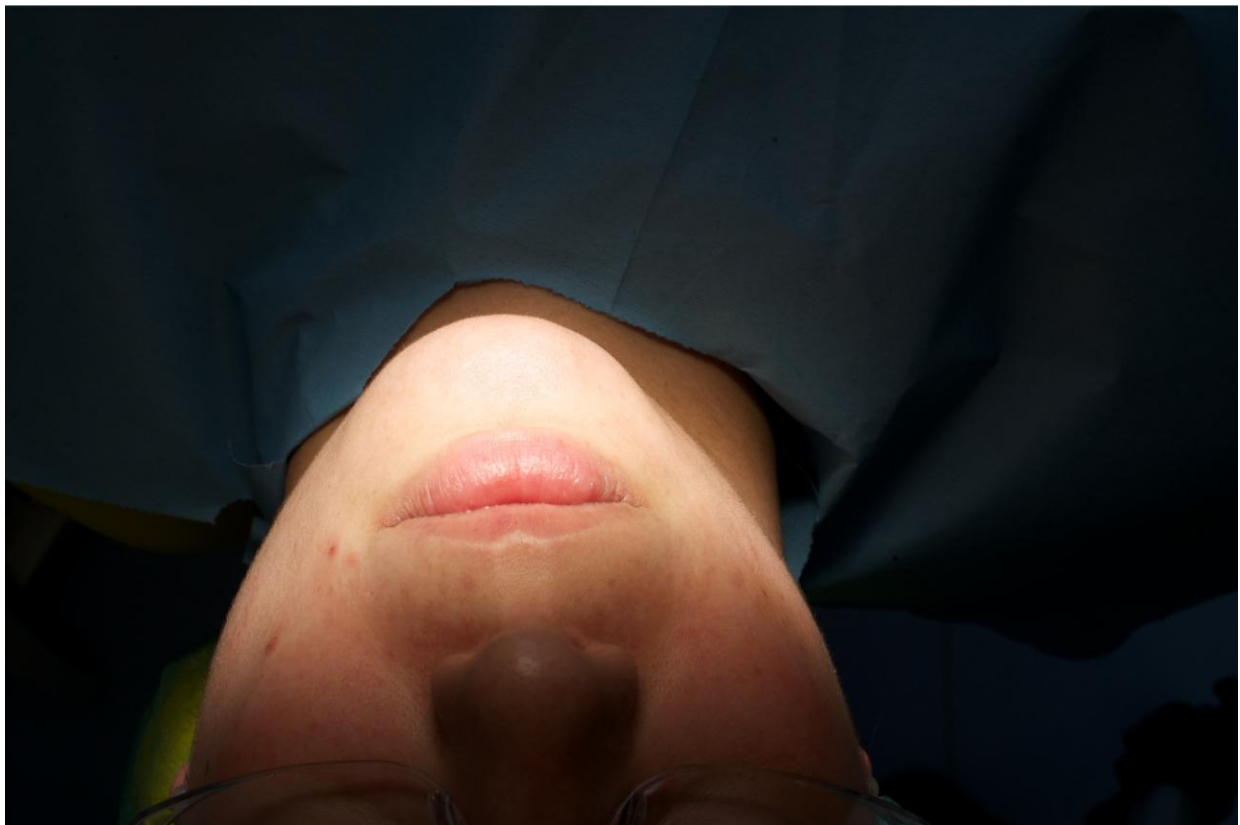
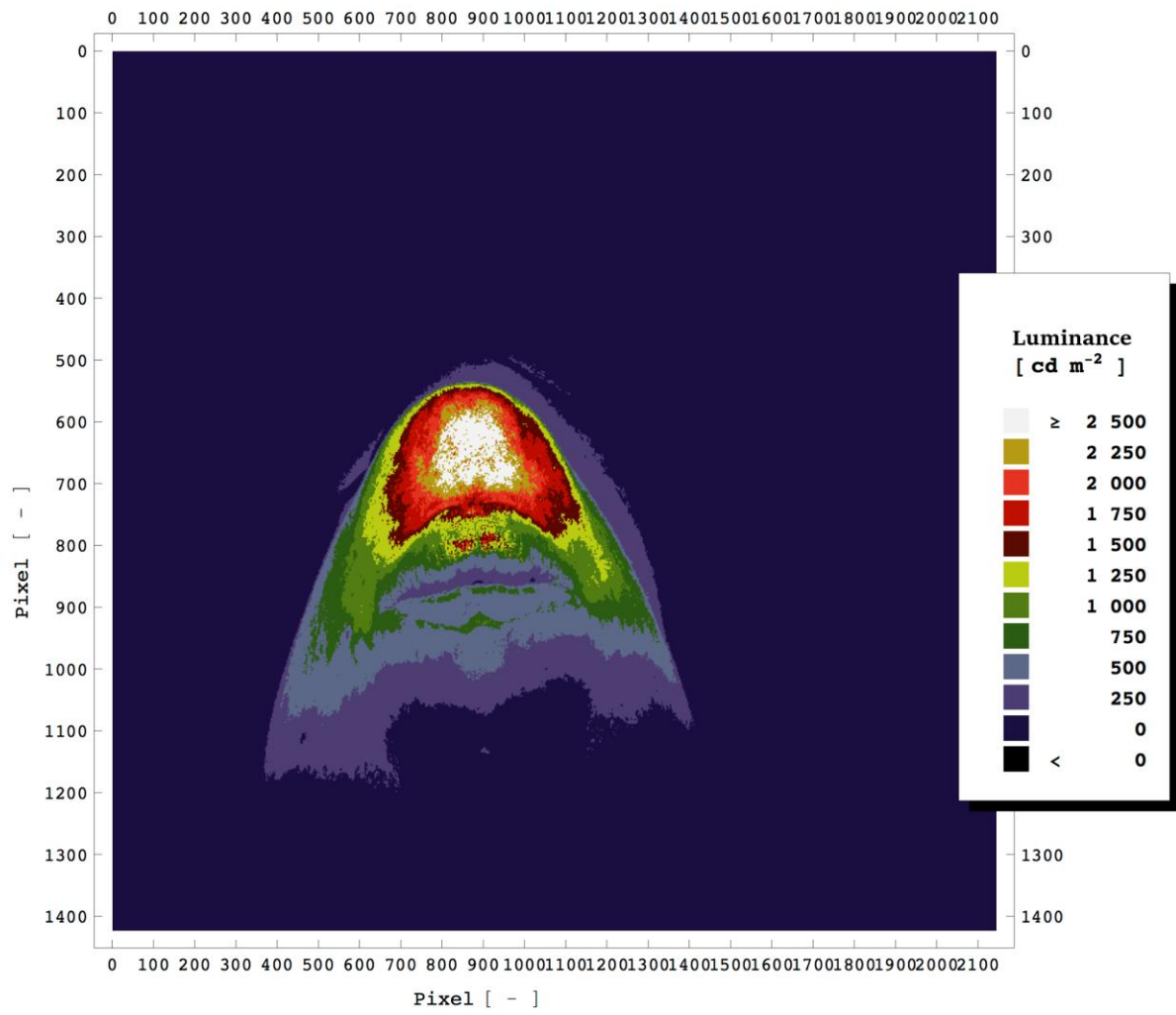

Figure 7. Dental Hygienist position “12 o’clock” luminance map, brand new protective shield. No lights from specular reflection in the visual field.

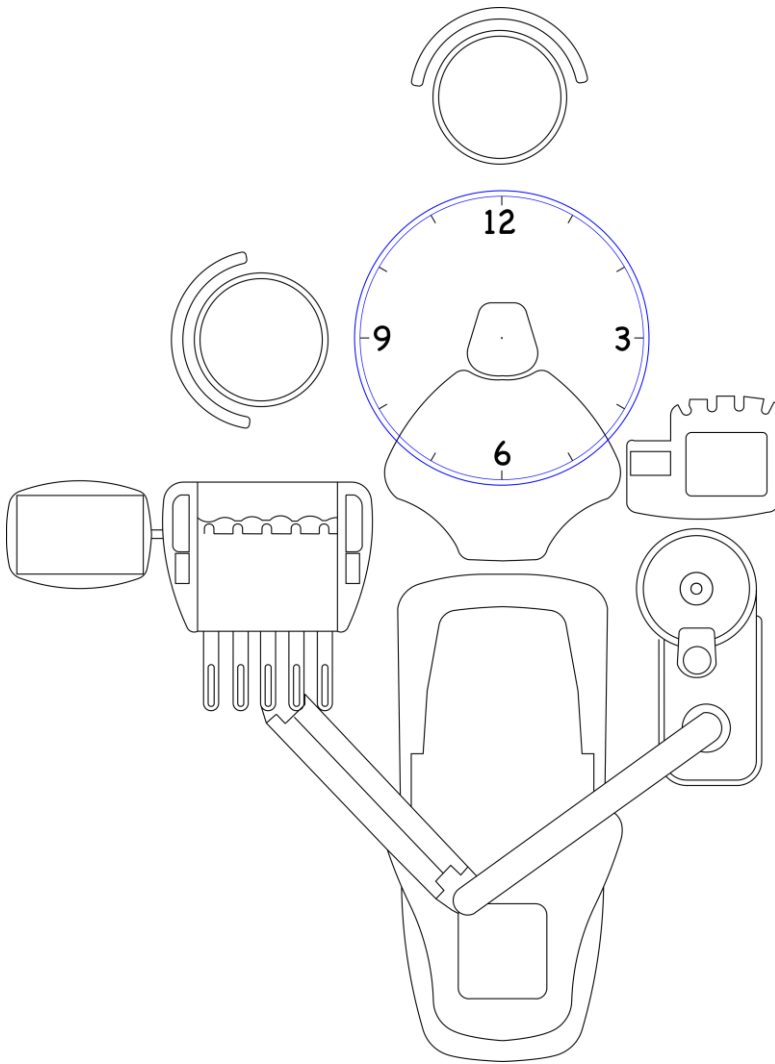

Figure 8. Dental Hygienist “9 o’clock” and “12 o’clock” positions. The “12 o’clock” position should be used whenever possible because in “9 o’clock” practitioners are more subjected to glare and related disorders.

4. Conclusions

The on field measurements, luminance maps (Figure 4 to Figure 7) and isolux graph (Figure 2) clearly demonstrated that the operating field is very high lighted: illuminance between 10 and 16 klx (illuminance on office desk is about 0,5 klx) and luminance higher

than 1 kcd/m² (a computer displays is about 0,25_kcd/m²), but even with such high values the contrast⁶ is low and colour contrast plays a relevant role in the details discrimination. This is noticeable in the luminance maps: the whole operating field is more or less of the same false colour, so the luminance is about the same. In this visual condition the perception depends on the difference between colours of the lighted surfaces. But colour discrimination relies on colour rendering capabilities of the source that are show in Table 3. In our investigation we measured the colour rendering properties of the source in two different point in the operating field, while ISO 9680:2007 standard requires the measurement of Ra and Ri just on one point on the reference plane. Because the Ra and Ri values measured in two different points are different, the dental hygienist can perceive differently the same colour depending on its position on the operating field, but we have to keep in mind that, in this working condition, visual perception is mostly based on colour differences than in luminance contrast.

The glare in the FOV depends on the practitioner position relative to the patient and to the lighting fixture. The comparison of luminance maps in Figure 5 and Figure 7 clearly shows the different behaviour of practitioner head and protective shield against the spatial luminous intensity distribution of the lighting fixture depending on the practitioner position around the patient. In Figure 5, the practitioner's head intercept the light and inter-reflection on the protective shield produce the glare disc. To avoid glare from inter-reflection due to lighting fixture, is suggested to use, when possible, the working position at "12 o'clock" (Figure 8), in the "9 o'clock" position practitioners are more subject to glare and MSD occurrence due to misplacement to increase the visual performances, although this research can be a first step towards a more attentive design of luminous intensity

⁶ The contrast is the relative ratio of object and background luminance.

distribution of dental lamps. To care about the dental practitioner visual comfort and performances a better design of dental lamps is necessary. In particular the luminous intensity spatial distribution should be more symmetrical, avoiding large differences in the lateral distribution flux. In this case the head of the practitioner, also when working in the “9 hour” position, will not intercept the light, and the direct reflection of luminous source on the eye protection device will not arrive.

This research demonstrated also that the normative requirements are not sufficient to assure the best perceptive conditions for dental hygienist to prevent performances degradations and long-term fatigue. Unfortunately the regulations in force are based on outdate concept to assure a “large quantity” of light (i.e. illuminance) for doing critical work, instead of high quality of lighting. CEN and Technical committee in CIE (Commission International de l'Éclairage, the scientific body about light and vision) are working on this new concept of lighting quality, the first application is in road lighting standards: new quality parameters will be introduced in the new regulation EN 13201 “Road lighting”. The necessity for this new approach is recognized also in the Dentistry Light Standard, we suggest that practitioners ask for data about colour rendering capabilities of lighting fixture, to push manufacturers toward a high quality design of lighting fixture, and prefer lighting fixture with symmetrical lighting distribution around the two main axis (9 and 12 o'clock respect to patients head).

Finally, we remark our initial statement that “Lighting of Quality” doesn't necessarily means “Lighting of Quantity”. Practitioners should be aware that the best lighting fixture for the dental workstation is not the one providing only the highest luminous levels.

For assuring new paradigms of design, that take care of lighting quality, studies and field researches based on quantities and methodologies able to characterize the people visual behaviour, are necessary: this one is a first step forward.

5. References

EN 12464-01:2011 Lighting of work place – Indoor work places, CEN

[EN 13201-4:2016 Road Lighting: Part 3 Calculation of performances](#), CEN

[EN 13201-4:2016 Road Lighting: Part 4 Methods of measuring lighting](#), CEN

EN ISO 9680:2007 Dentistry – Lamps, ISO

[ISO 9241-305:2009, Ergonomics of human-system interaction. Part 305: Optical laboratory test methods for electronic visual displays](#), ISO

CIE 17.4:1987 Commission Internationale de l'Eclairage CIE: 'International Lighting Vocabulary', Vienna, CIE

CIE 117:1995 Commission Internationale de l'Eclairage CIE: 'Discomfort glare in interior lighting' [Vienna](#) CIE 1995

[CIE 145:2002 Commission Internationale de l'Eclairage, CIE: 'The correlation of models for vision and visual performances'](#), Vienna, CIE 2002

CIE 147:2002 Commission Internationale de l'Eclairage, CIE: 'Collection on glare', Vienna, CIE 2002

ADRIAN, W. 1993, The Physiological Basis of the Visibility Concept, Proceedings of 2nd International Symposium on Visibility and Luminance in Roadway Lighting October 26-27 1993 Orlando Florida

[P. Boyce, Human Factors in Lighting, Third Edition, CRC Press 2014](#)

P. Fiorentin, P. Iacomussi, G. Rossi, Characterization and calibration of a CCD detector for light engineering, IEEE Trans. on Instrumentation and Measurement, Vol. 54, no. 1, pp. 171-177, 2005

P. Iacomussi, G. Rossi, M. Castellano, The on site evaluation of performances of road lighting installations, Proceedings of Lux Europa, Berlin (D), September 2005

[IES, A guide to designing quality lighting for People and Buildings, Illuminating Engineering Society, 2009](#)

[Jwo-Huei Jou et al, A universal, easy to apply lighting quality index based on natural light spectrum resemblance, Appl. Phys. Lett. 104, 203304 \(2014\);
http://dx.doi.org/10.1063/1.4879635](#)

[MIL-HDBK-87213A : 2005, Electronically/Optically Generated Airborne Displays.](#)

G. Rossi, P. Iacomussi, L. Rossi, D. Renoux, J. Nonne: Measurement Procedure of visual confort. EMRP09 JRP Project ENG05, 2013 a

G. Rossi, P. Iacomussi, M. Radis, D. Renoux, J. Nonne: Applications Guidelines to improve visual confort. EMRP09 JRP Project ENG05, 2013b

L. Rossi, G. Rossi, P. Iacomussi, Intrinsic contrast vs perceived contrast, Perception 2010, Vol. 39, Supplement, pag. 168-170

G. Rossi, P. Iacomussi, M. Sarotto, P. Soardo, The measurement of UGR with a CCD based detector, Proceedings of Metrologie '99 International Congress, October 1999, Bordeaux (F)

G. Rossi, P. Iacomussi, M. Radis: Report on measurement conditions and parameters to correctly evaluate glare of SSL luminaires. EMRP09 JRP Project ENG05, 2013c

DIRECTIVE 2006/25/EC OF THE EUROPEAN PARLIAMENT AND OF THE COUNCIL on the minimum health and safety requirements regarding the exposure of workers to risks arising from physical agents (artificial optical radiation) (19th individual Directive within the meaning of Article 16(1) of Directive 89/391/EEC)

[Laike, T: An evaluation model for light environments, Ceebel Conference: Energy efficient lighting in a human perspective, August 2010 , Katrineholm](#)

Figure 1
[Click here to download high resolution image](#)

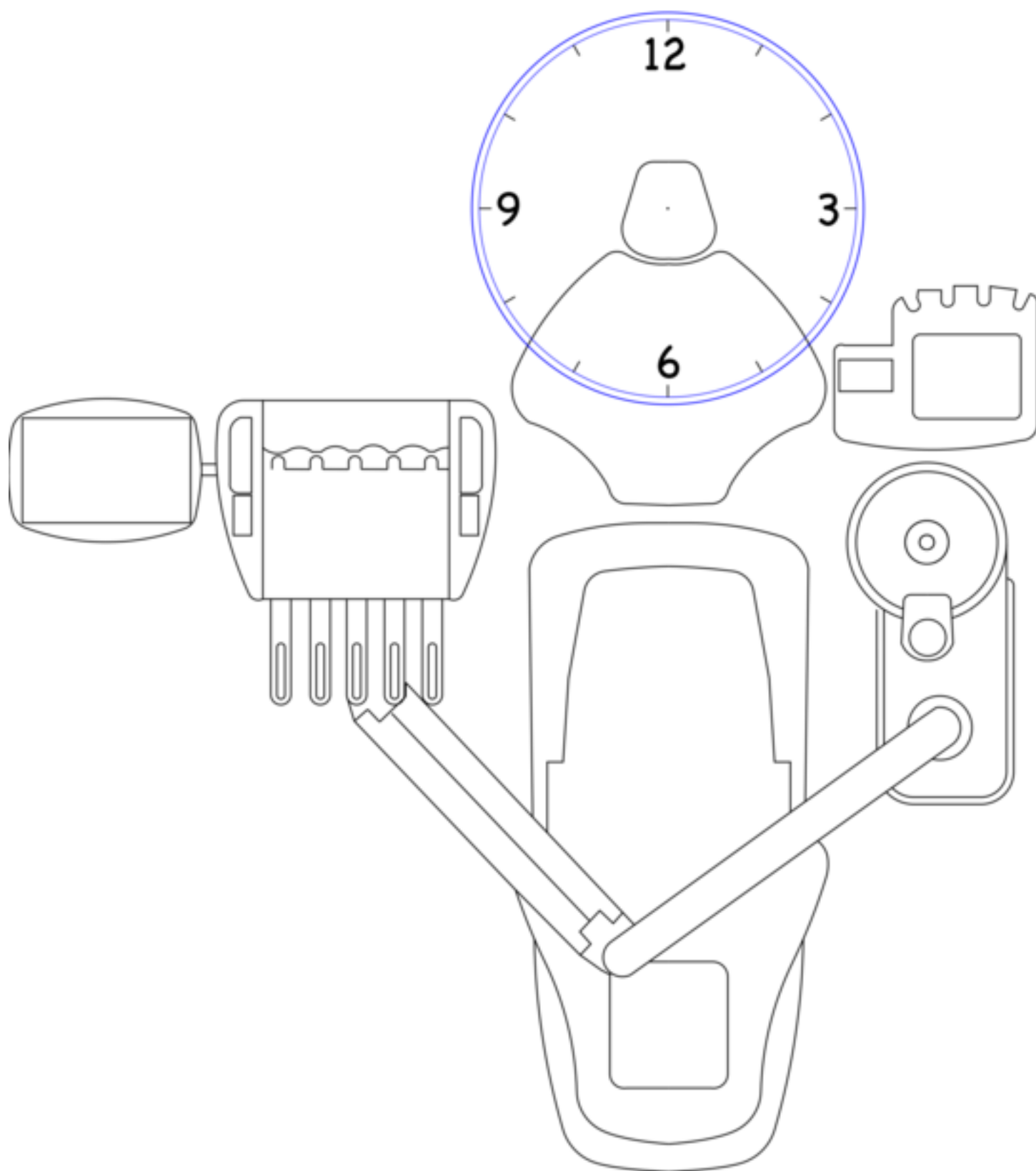

Figure 2
[Click here to download high resolution image](#)

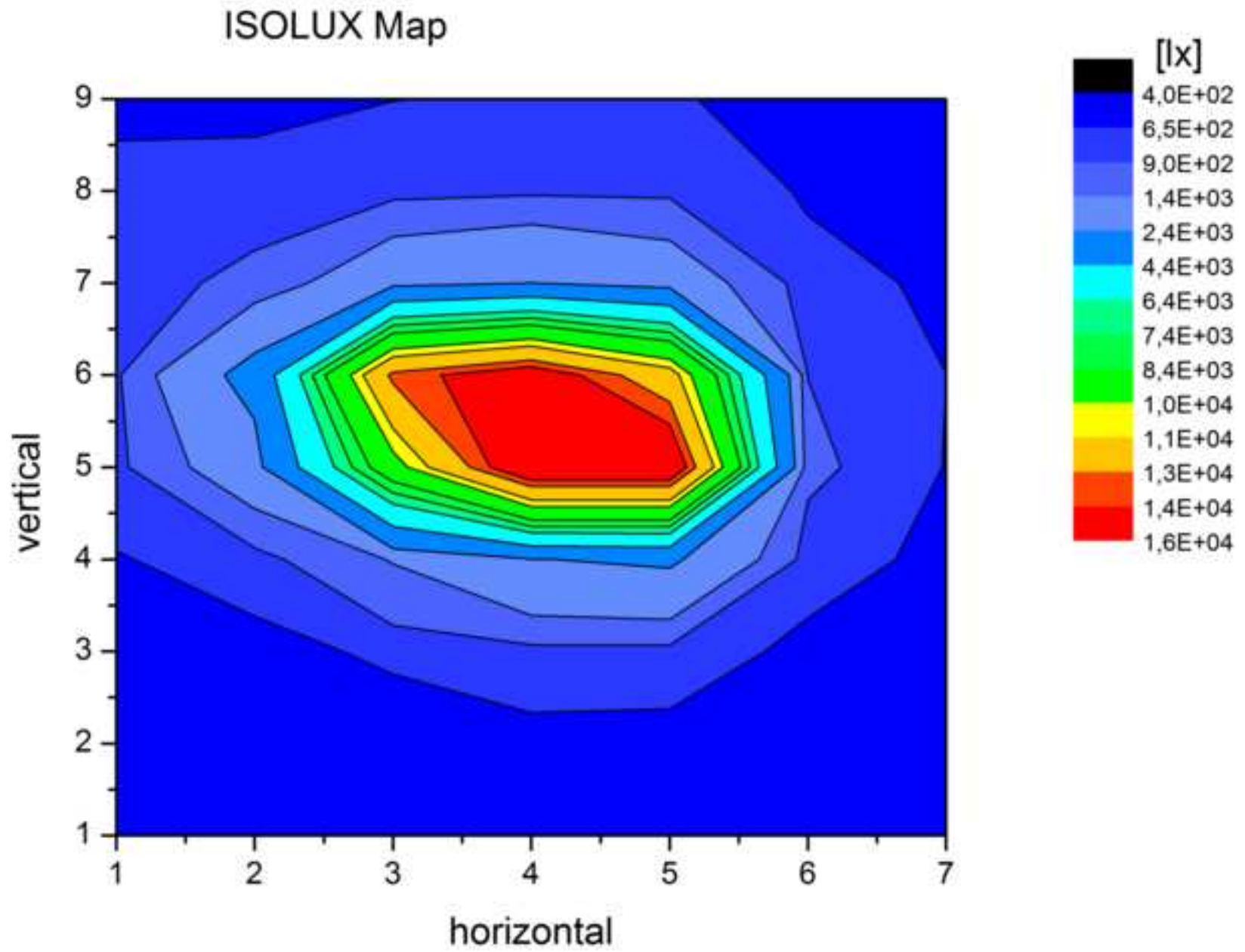

Figure 3
[Click here to download high resolution image](#)

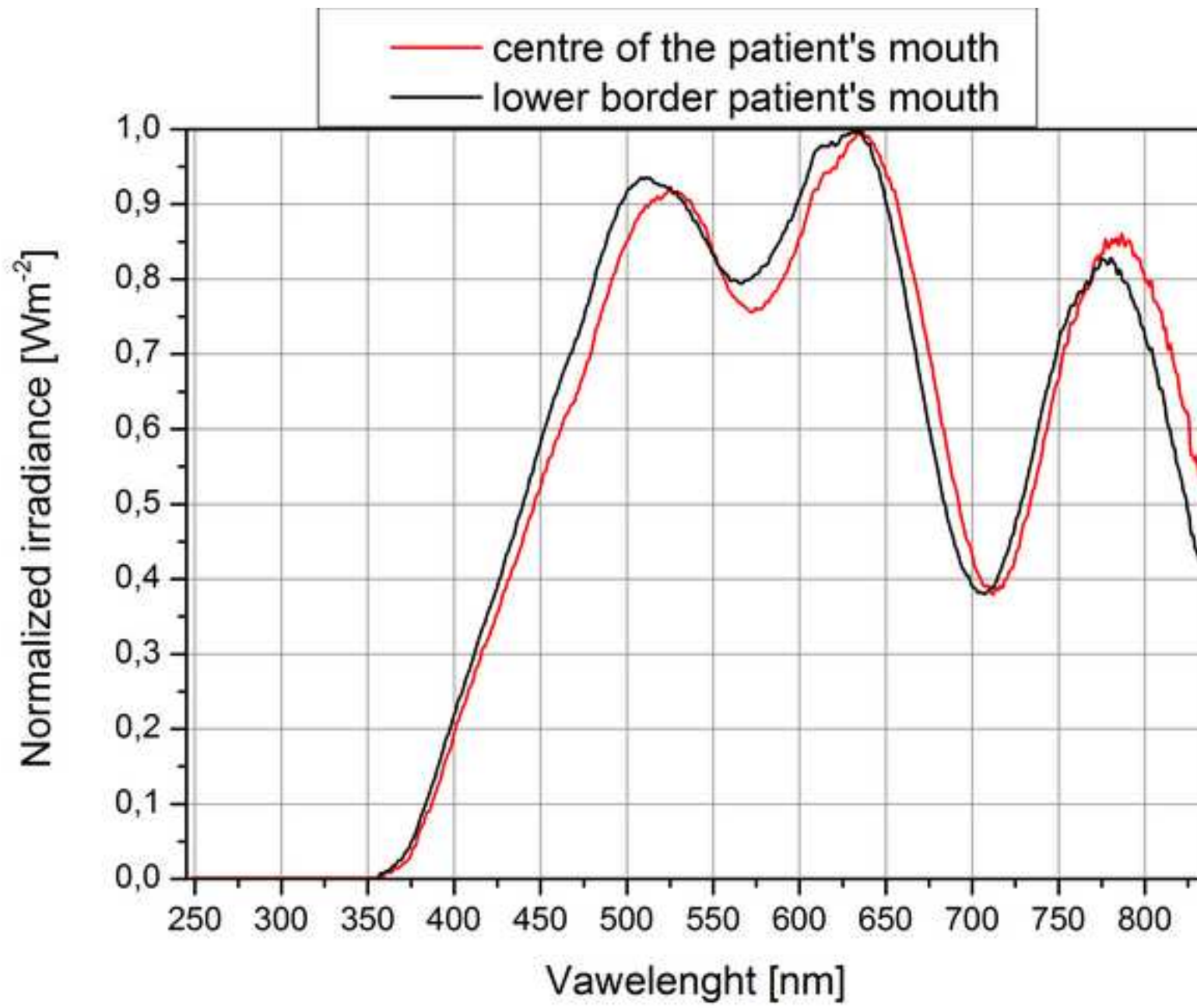

Figure 4

[Click here to download high resolution image](#)

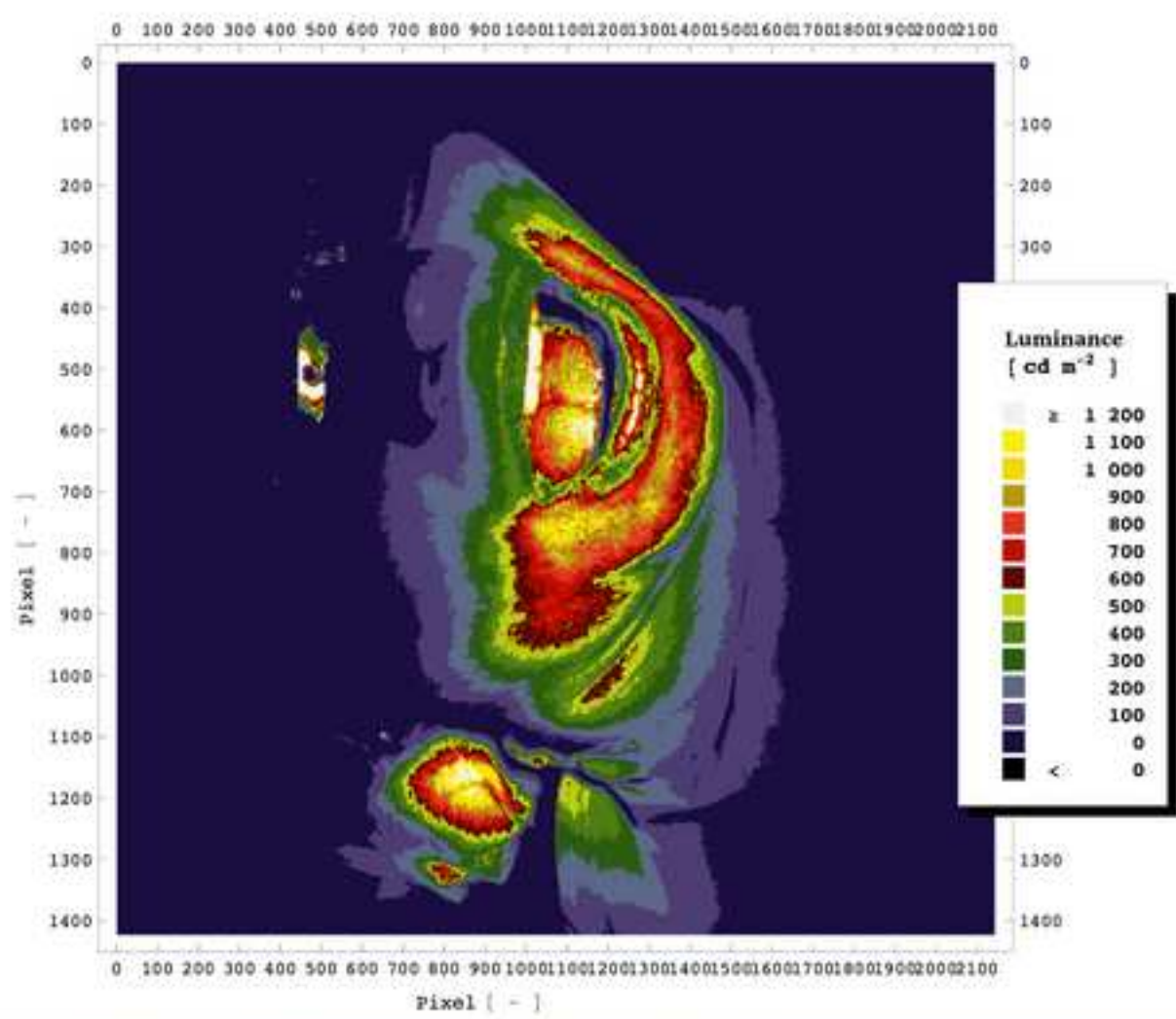

Figure 5

[Click here to download high resolution image](#)

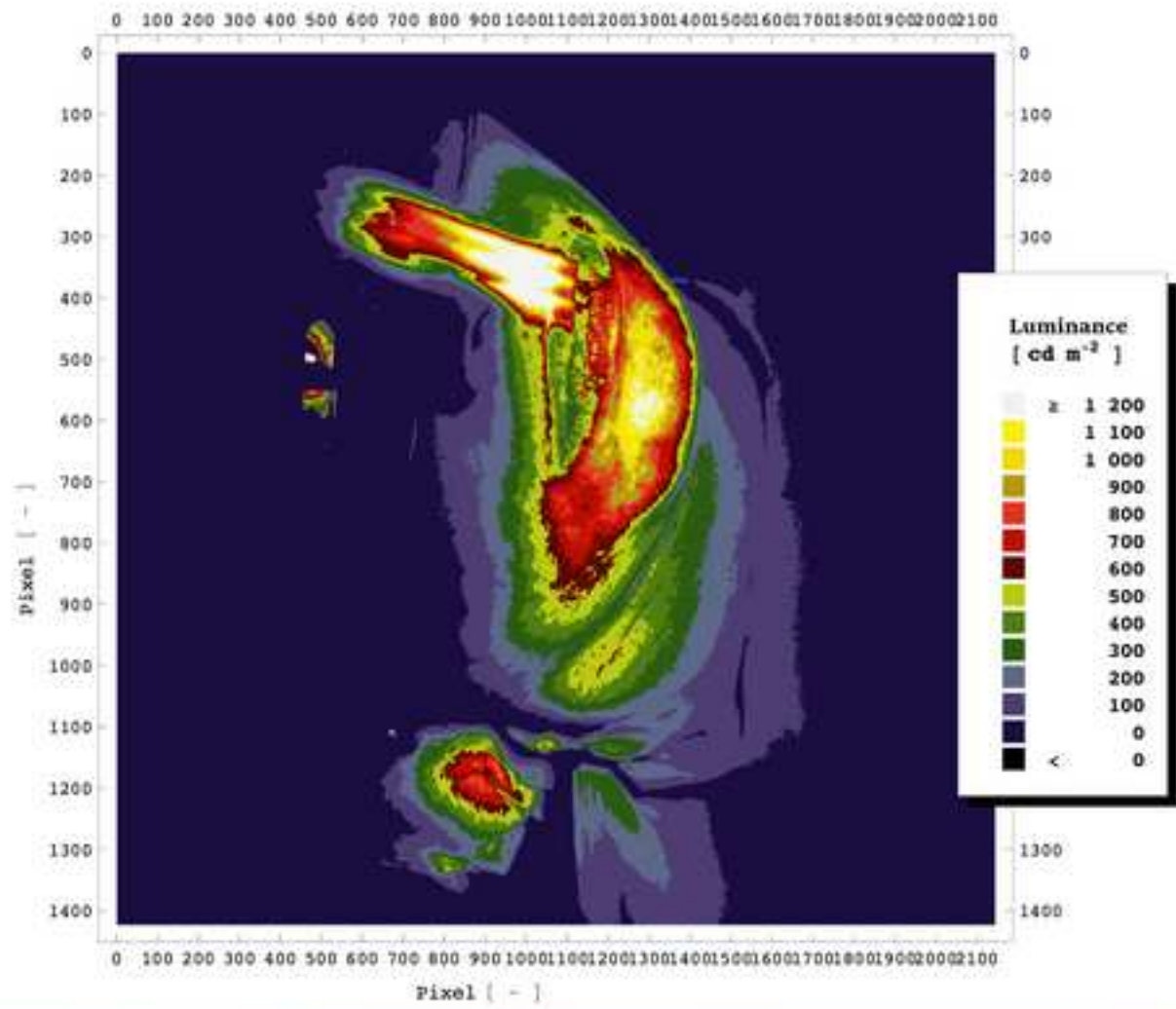

Figure 6

[Click here to download high resolution image](#)

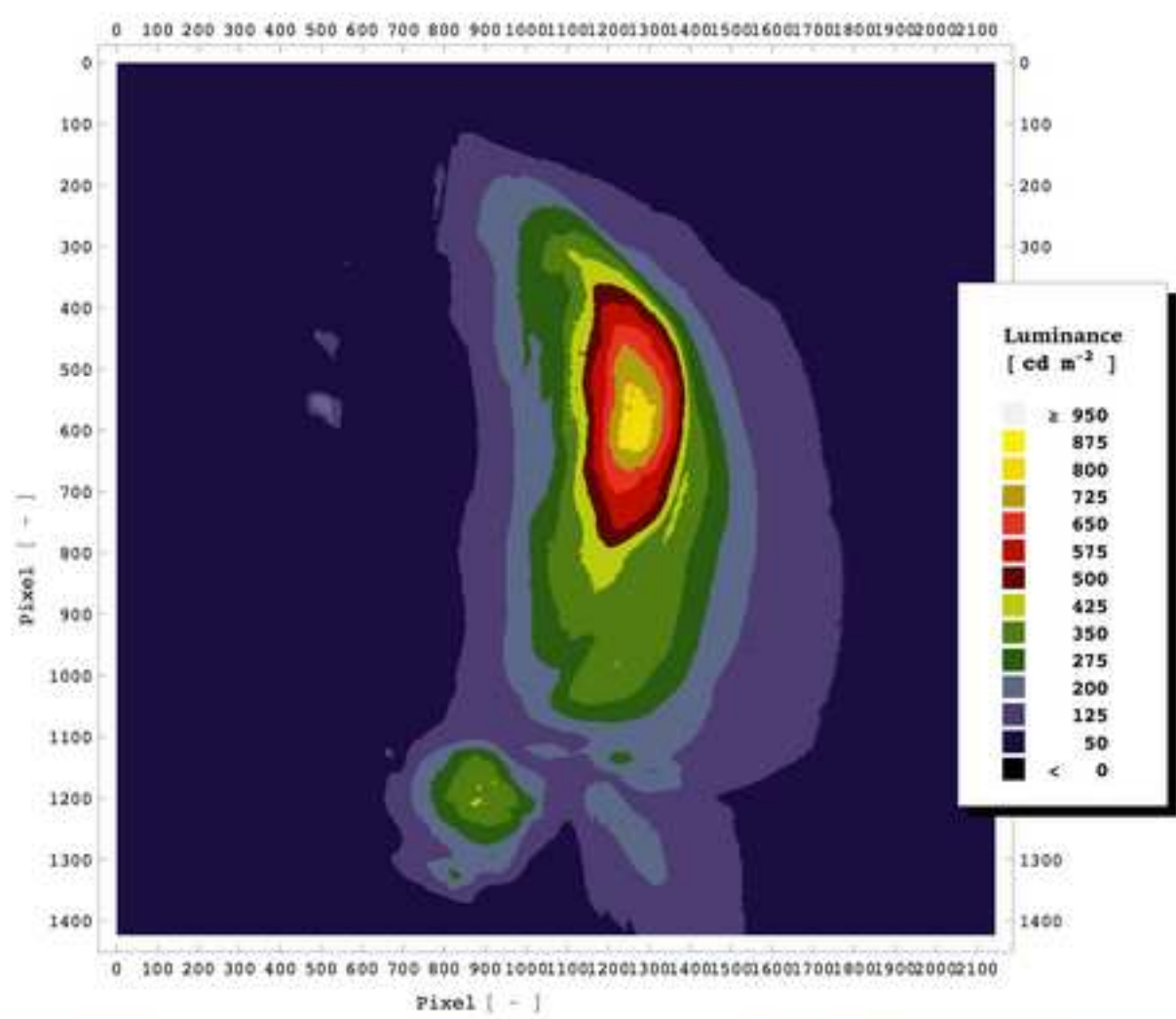

Figure 7

[Click here to download high resolution image](#)

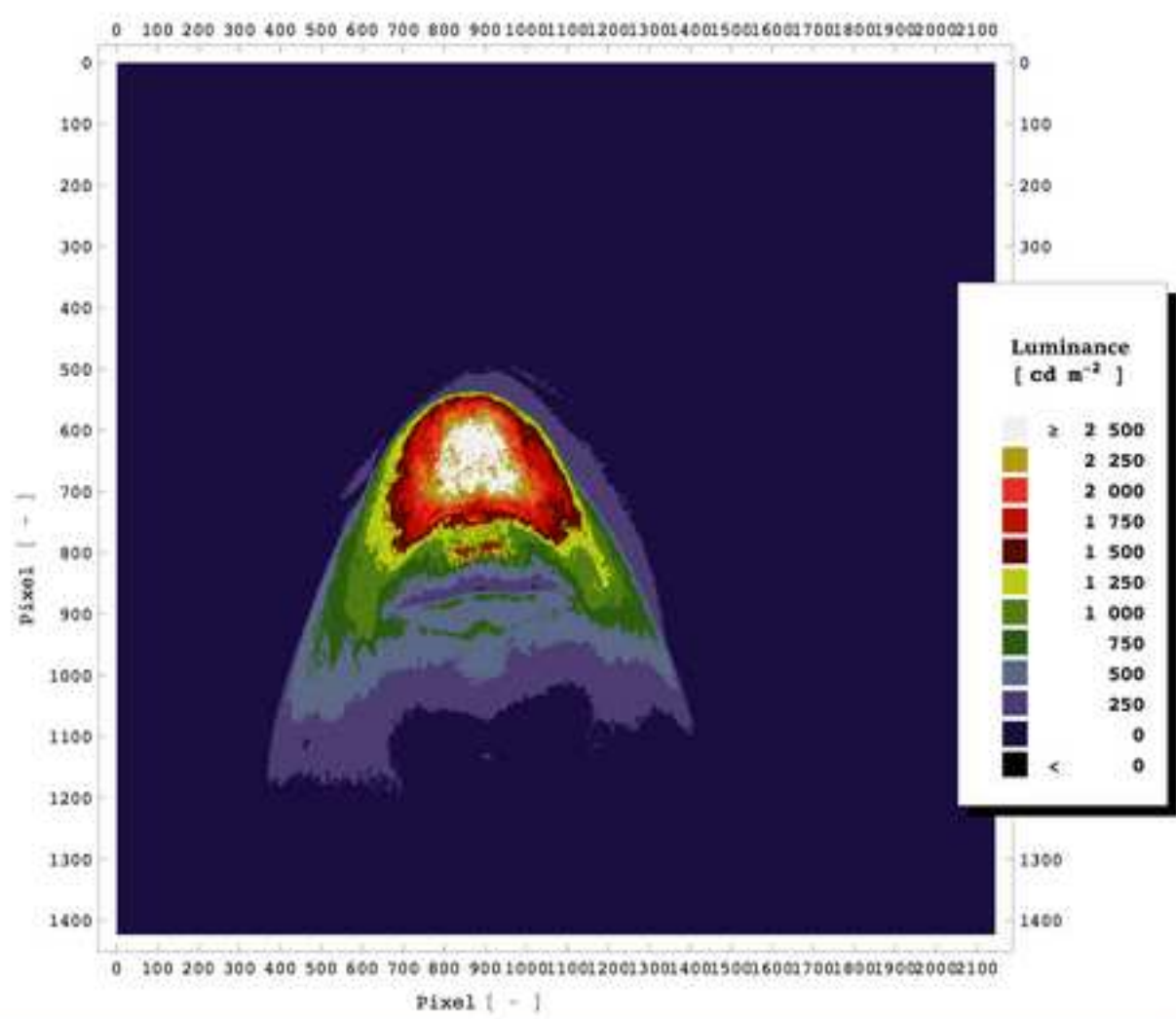
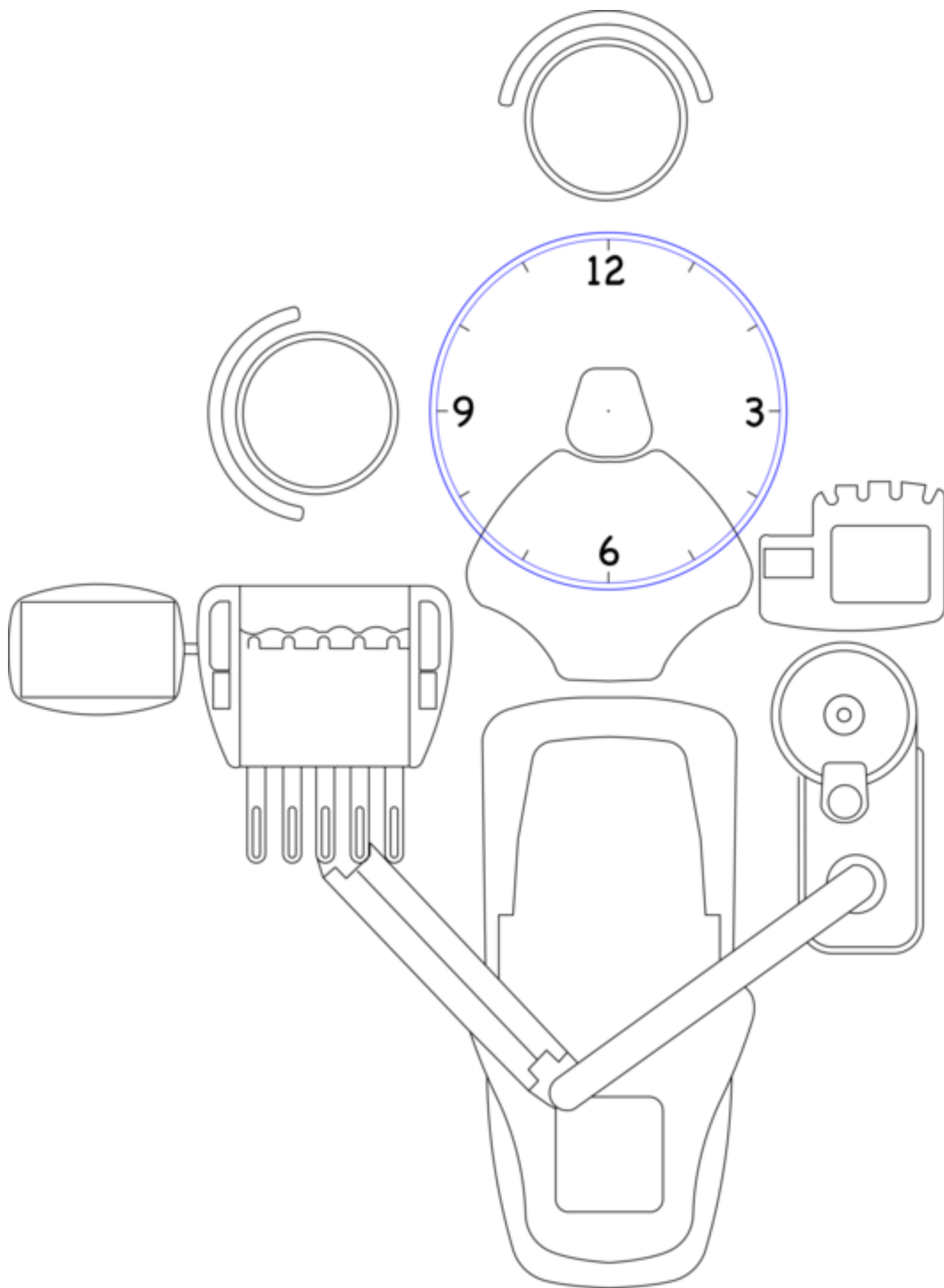

Figure 8
[Click here to download high resolution image](#)



Luminance Map	Measurement conditions	
	CCD luminancemeter position	Protective shield
Figure 4	9 hours	without shield
Figure 5	9 hours	brand new protective shield
Figure 6	9 hours	very wreckled shield
Figure 7	12 hours	brand new shield

Reference	Area of interest	Maintened Illuminance [lx]	UGR _L
5.48.1	General lighting	500	19
5.48.2	At the patient	1000	-
5.48.3	Operating cavity	-	-
5.48.4	White teeth matching	-	-

U₀	Ra	Requirements
0,6	90	Glare free for the patient
0,7	90	
-	-	Rif. EN ISO 9680
-	-	Rif. EN ISO 9680

Type of area cfr UNI EN12464	Normative requirement	Measured value (source in working condition)
	Maintened illuminance	Mean illuminance
	E [lx]	E_m [lx]
General lighting	500	900
At the patient	1000	700
Operating cavity	≥ 20000	16300 (max value)

Measured value (source in normative
Max illuminance
E_M [lx]
-
-
25500

Table3 in pdf

Point of measurement in the lighted field	CCT [K]	Ra Index	Ri 9 (red)	ΔE red sample	Ri 10 (yellow)	ΔE yellow sample	Ri 13 (human complexion)	ΔE human complexion sample
At the centre	4550	95	92	2	90	2	94	3
Lower border of the patient's mouth	4460	95	85		93		94	

Luminance Map	Measurement conditions	
	CCD luminancemeter position	Protective shield
Figure 4	9 hours	without shield
Figure 5	9 hours	brand new protective shield
Figure 6	9 hours	very wreckled shield
Figure 7	12 hours	brand new shield