



ISTITUTO NAZIONALE DI RICERCA METROLOGICA Repository Istituzionale

Determination of the Boltzmann constant k from the speed of sound in helium gas at the triple point of water

This is the author's accepted version of the contribution published as:

Original

Determination of the Boltzmann constant k from the speed of sound in helium gas at the triple point of water / Pitre, L; Risegari, L; Sparasci, F; Plimmer, M D; Himbert, M E; Giuliano Albo, P A. - In: METROLOGIA. - ISSN 0026-1394. - 52:5(2015), pp. 263-273. [[10.1088/0026-1394/52/5/s263](https://doi.org/10.1088/0026-1394/52/5/s263)]

Availability:

This version is available at: 11696/65519 since: 2022-05-20T08:02:16Z

Publisher:

IOP

Published

DOI:[10.1088/0026-1394/52/5/s263](https://doi.org/10.1088/0026-1394/52/5/s263)

Terms of use:

This article is made available under terms and conditions as specified in the corresponding bibliographic description in the repository

Publisher copyright

Institute of Physics Publishing Ltd (IOP)

IOP Publishing Ltd is not responsible for any errors or omissions in this version of the manuscript or any version derived from it. The Version of Record is available online at DOI indicated above

(Article begins on next page)

Determination of the Boltzmann constant k from the speed of sound in helium gas at the triple point of water

L. Pitre, L. Risegari, F. Sparasci, M.D. Plimmer and
M.E. Himbert

LNE-CNAM, La Plaine-Saint-Denis, France

P.A. Giuliano Albo

Istituto Nazionale di Ricerca Metrologica, Thermodynamics Division, Torino, Italy

E-mail: laurent.pitre@cnam.fr

Abstract. The Boltzmann constant k has been determined from a measurement of the speed of sound in helium gas in a quasi-spherical resonator (volume 0.5 l) maintained at a temperature close to the triple point of water (273.16 K). The acoustic velocity c is deduced from measured acoustic resonance frequencies and the dimensions of the quasi-sphere, the latter being obtained via simultaneous microwave resonance. Values of c are extrapolated to the zero pressure limit of ideal gas behaviour. We find $k = 1.380\,648\,7(14) \times 10^{-23} \text{ J}\cdot\text{K}^{-1}$, a result consistent with previous measurements in our group and elsewhere. The value for k , which has a relative standard uncertainty of 1.02 ppm, lies 0.02 ppm below that of the CODATA 2010 adjustment.

PACS numbers: 06.20.Jr Determination of fundamental constants, 07.20.-n Thermal instruments and apparatus, 43.58.-e Acoustical measurements and instrumentation

Keywords: Acoustic resonance, Boltzmann constant, Definition of the kelvin, Microwave resonance, Quasi-sphere, Speed of sound, Triaxial ellipsoid

Submitted to: *Metrologia*

1. Introduction

1.1. Historical overview and motivation

The SI unit of temperature, the kelvin, is currently defined as $1/273.16$ of the temperature of the triple point of water (TPW). The relative uncertainty of triple-point standards is below 2×10^{-7} [1, 2], but the present definition suffers from two major drawbacks. First, thermometry at the 10^{-6} level of accuracy is only possible

for temperatures close to TPW. Secondly, it can be very complicated to trace a thermometer over a temperature range of several decades. A future definition of the base unit will use a fixed value of the Boltzmann constant k [1] so as to be universal, immune from the drifts inevitable with water filled cells and allow higher accuracy thermometry across a temperature scale spanning hundreds of kelvin. While k will be fixed with zero uncertainty, it is desirable that the most accurate and reliable value of the constant be established to ensure a smooth transition from the current definition to the new one. Historically, the Boltzmann constant has been determined in a number of different ways [3, 4]. While the most accurate experiments have been based on the speed of sound in a monatomic gas [5, 6, 7, 8], other determinations have been based on the refractive index or dielectric constant of a gas at known temperature and pressure [9, 10, 11] or the Johnson noise in a resistance [12]. Laser resonance experiments that determine the Doppler width of molecular absorption, though not as accurate, use a completely different technique and could provide a useful cross-check of other results (see *e.g.* [13] and references therein). In this article we describe our most recent determination of k via the measurement of the speed of sound in helium vapour. It follows an earlier determination by our group using argon gas [7] with a similar apparatus. We outline some of the improvements made to the set-up and indicate differences between measurements with helium and argon. Since similar experiments are underway elsewhere, we underline key differences between the apparatus and procedure used here compared with other work. While the resonator, its dimensional measurement and thermometry are identical with those of the earlier experiment, the acoustic frequency measurements and gas handling are completely independent. The degree to which the present measurement is correlated with previous ones is currently being evaluated by the BIPM CCT WG4 on behalf of CODATA [14].

In keeping with the spirit of our publication on the measurement of k with argon [7], we state herewith the result and uncertainty : $k = 1.380\,648\,7(14) \times 10^{-23} \text{ J}\cdot\text{K}^{-1}$. Table 1 gives the global error budget. Figure 1 shows a comparison of recent determinations of the Boltzmann constant. The present result, with a standard uncertainty of 1.02 ppm, lies in good agreement with measurements in our own group and most of those elsewhere. Our value lies 0.02 ppm below that of the CODATA 2010 adjustment [15], *i.e.* it differs from it by much less than the standard error.

In the next section (2) we give the principle of the experiment. Thereafter (section 3) we outline the apparatus. The measurement of acoustic resonance frequencies is described in section 4 and the remaining aspects of the experiment (resonator geometry, pressure measurement, gas handling and thermometry) in section 5. The results are summarised and a conclusion given in section 6.

2. Principle of the experiment

The basis of the experiment is the measurement of the speed of sound in a gas of known molar mass at a given temperature. A resonator maintained at a temperature as close

Table 1. Uncertainty budget for the present determination of the Boltzmann constant using ^4He . The figures correspond to standard uncertainties. Details of the acoustic and gas purity contributions are presented in sections 4 and 5.3. The thermometry and volume uncertainties are discussed in depth in [7].

Term	Relative uncertainty (10^{-6})
Acoustic frequency	0.62
Resonator volume	0.57
Molar mass and gas purity	0.53
Thermometry	0.30
Total (square root of quadratic sum)	1.02

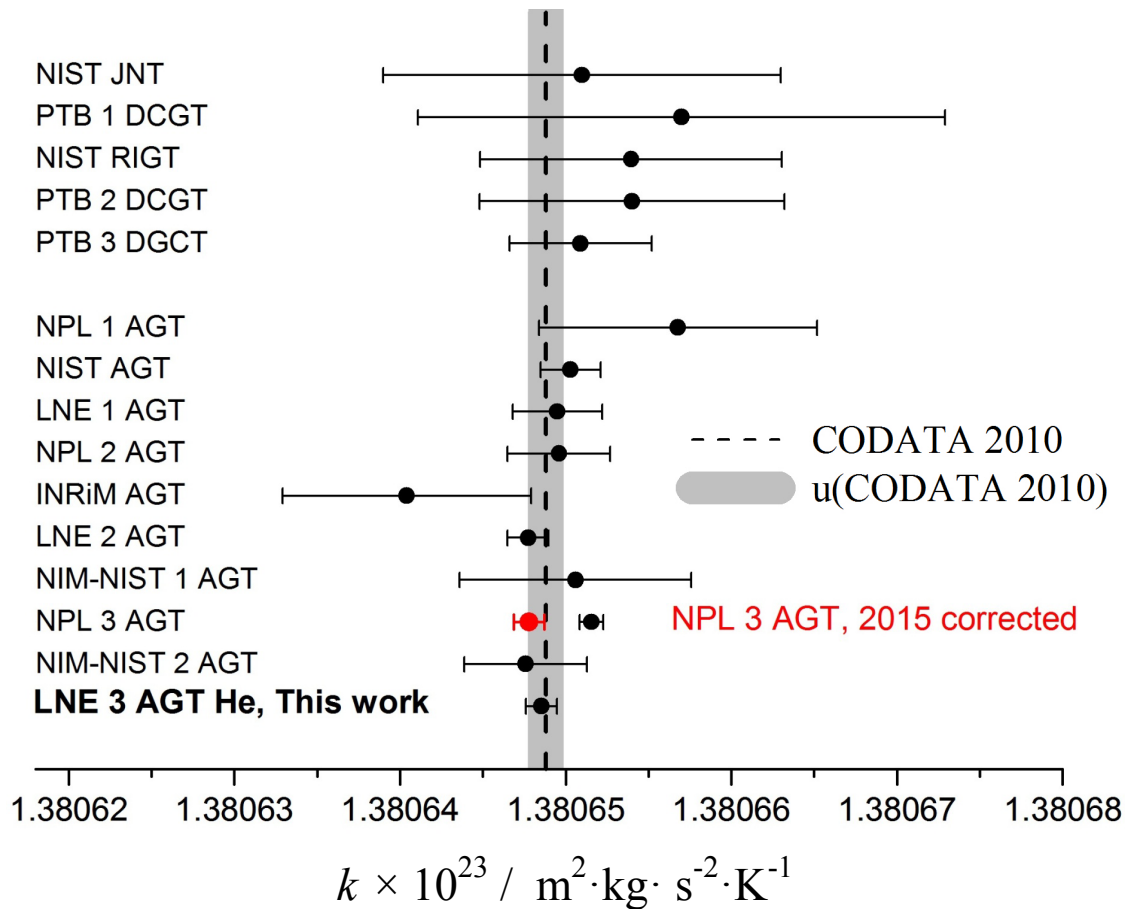

Figure 1. Comparison of determinations of the Boltzmann constant since 1979. Key : AGT (acoustic gas thermometry), JNT (Johnson noise thermometry) ; RIGT (Refractive-index gas thermometry) DCGT (Dielectric constant gas thermometry); References: CODATA2010 [15]; INRIM [6]; LNE 1 [16], LNE 2 [7]; NIST RIGT [17]; NIST JNT [12]; NPL 1 [18], NPL 2 [19], NPL 3 [8]; NIM-NIST 1 [20], NIM-NIST 2 [21]; PTB 1 [9], PTB 2 [10], PTB 3 [11]. The values of NPL-3 and LNE-2 include corrections arising from recent, independent determinations of argon gas [22] composition.

as possible to 273.16 K and through which there flows a gas of the highest purity is excited by acoustic waves. From the measurement of the resonance frequencies and

resonator dimensions, one determines the acoustic velocity. Together with the values of molecular mass and temperature, this leads to a value for the Boltzmann constant. Before describing the details of the experiment and some subtleties of the underlying assumptions, we justify the choice of gas and resonator geometry.

2.1. Choice of gas

For an ideal gas consisting of molecules of mass m at a temperature T the speed of sound c is linked to the Boltzmann constant k via

$$c^2 = \frac{C_p kT}{C_v m} \quad (1)$$

where C_p and C_v denote respectively the specific heat capacities at constant pressure and volume. For diatomic and polyatomic molecules, the heat capacity is a function of temperature. For a monatomic gas, however, the ratio C_p/C_v is simply equal to 5/3. Furthermore, it is only for these gases that acoustic boundary layer corrections can be calculated at the 0.05 % level [23], which affects the relative value of k by 0.1 ppm (see equation 6). Thus, only noble gases are used for measurements of k by acoustic thermometry. When a real gas is used, virial corrections that depend on the pressure p at which the measurements are performed must be applied to the ratio C_p/C_v . One can either calculate these corrections for each pressure [6] or, as here, determine the speed of sound for the gas at several different pressures and extract the pressure-independent part of the result. Ideally, one would like to measure the Boltzmann constant using several different noble gases and hence values of m . In practice, the choice of gas is governed by issues relating to isotopic abundance, purity and, in the case of helium-3, cost. Xenon has nine stable isotopes while krypton has six [24]. One needs to know the value of m at a level of $< 10^{-6}$ which is currently not possible for either of these gases for which no single isotope is predominant. As alternatives to argon used in our previous measurement and elsewhere, there remain neon and helium. *A priori* helium-4 has the advantage over argon of chemical purity since all other species bar helium-3 can be eliminated from the source bottle with the aid of a cold trap. On the other hand, the mass is much smaller compared to the other possible impurity, so the effect on the speed of sound of any impurity will be greater, as explained in [5]. Another advantage of using helium for acoustic measurements is that while the boundary layer correction can be evaluated using *ab initio* calculation for both gases, the relative uncertainty in the correction for helium [23] is smaller than it is for argon. We note finally that a measurement of k with helium-3 would provide an interesting cross check of the present work were the gas to become affordable in future [25].

2.2. Resonator geometry

For plane standing waves, where the modes are sinusoidal, the speed of sound is given by the product of frequency and wavelength, the latter being determined by the dimensions of the resonator once the order of a given mode is known. For spherical waves, where

the modes are given by Bessel functions whose nodes are unequally spaced, the term wavelength is no longer appropriate. However, the mode number and resonator size still provide the link between sound velocity and frequency. The simplest case is that of a spherical resonator and was used for the determination of k by Moldover and colleagues in 1988 [5]. The most accurate determinations of k since then have employed refinements of the same technique. In the original experiment, as spherical a resonator as possible was used, the volume of which was determined by the gravimetry of a liquid of known density. The experiment described here uses a slightly ellipsoidal resonator, the lengths of whose three axes are measured by microwave resonance. At the time of Moldover's measurement, this was not technically possible but modern, diamond-turning techniques allow one to manufacture such an exotic shape. The asphericity is chosen to be large enough to allow closely-spaced resonances to be clearly resolved yet sufficiently small that perturbations arising from the shape deformation remain acceptably low. (The relative shift in the present case is a few times 10^{-5} .) Note that an alternative resonator shape, a cylinder, has been used successfully in recent measurements of the Boltzmann constant by Lin *et al.* [26], albeit for a relative accuracy of 3.7×10^{-6} .

3. Apparatus

The experimental set-up consists of an ellipsoidal copper resonator held in a thermostat at a temperature close to TPW into which flows helium gas. Microphones flush with the internal surface the resonator are used to measure acoustic resonances while internal antennæ are used for microwave measurements. Ultra-pure gas is supplied via one or two cold traps and its pressure is both measured and servo-controlled. Capsule standard platinum resistance thermometers (CSPRTs) used to link the measurement to the TWP. Aside from the gas handling and measurement of acoustic resonances, the basic apparatus, already described extensively elsewhere [7], is the same as that used for measurements with argon. It differs from those of [6] and [8] in that it uses an isentropic thermostat (Figure 2), the design of which was inspired by that of cryostats used for work at temperatures around 4.2 K. This allows one not only to measure the average temperature of the resonator but also obtain a detailed breakdown of the different sources of heat (gas flow, microwaves, acoustic waves, room temperature variations). To do this, the heat shield is maintained at a constant temperature while the temperature of the outer heat bath is altered. In this way, one can switch off a particular source of heat (*e.g.* microwaves) then change the temperature of the outer heat bath to compensate for the loss. Note that when the power is changed, the difference in the temperature read by the CSPRTs and that deduced independently by acoustic thermometry remains constant whatever the source of heat power, as listed in table 2. This implies that not only is the temperature highly uniform throughout the body of the resonator but there is also excellent temperature homogeneity between the gas and the metallic surface. Because the time constant of the CSPRTs thermometers and measurement bridge is about 2 min, it is easier to track temperature changes on minute-long timescales using

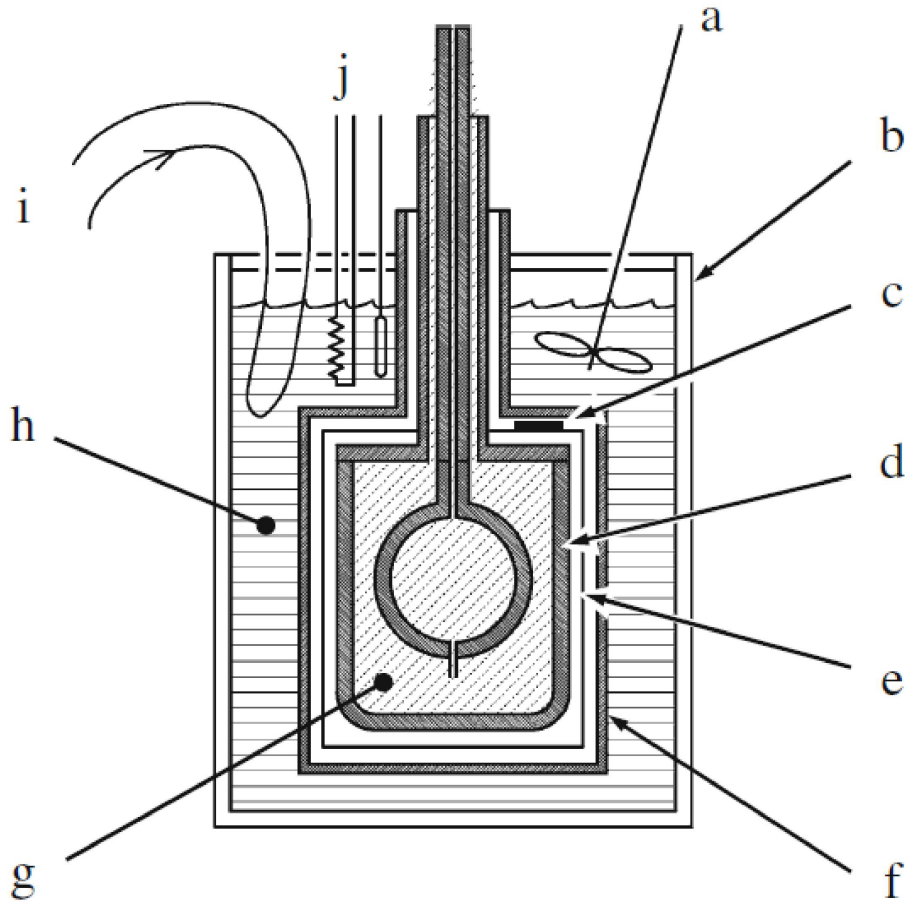

Figure 2. Schematic diagram of the sphere in the thermostat: a stirring propeller, b Dewar, c heater, d pressure vessel, e radiation shield, f vacuum vessel, g Ar or He gas, h water + ethylene glycol bath, i cooler, j heater. Taken from [7].

Table 2. Power contributions of different heat sources. See figure 3 for the definition of the unit sccm.

Heat source	Power (μW)	Standard uncertainty (μW)
Acoustic pre-amplifier	130	10
Microwave power +10 dBm	890	10
Microwave power -10 dBm	85	10
Gas flow 10 sccm to 50 sccm	0	10

acoustic frequency measurements than by contact thermometry; the method is faster but of comparable resolution.

Once the temperature of the resonator has been set to its working point close to TPW, it is verified that the temperature homogeneity of the sphere remains unchanged at the level of 0.1 mK. The thermostat is not of course perfectly adiabatic. However, even when the room temperature changes by ± 3 °C, that of the resonator is affected

only at the level of a 0.1 mK (drift 0.1 mK/h) if the temperature of the heat shield is kept constant. To cancel the effect of an ambient temperature change, we alter the temperature of the heat shield. In this way, the drift of the resonator temperature is limited to 0.1 mK/day. Since the time constant τ for thermalisation of the 0.5 l sphere is 4 h, this implies that the temperature difference between the shell and the gas is less than 16 μ K.

Microwave resonance is used to determine the resonator dimensions. Aside from a different refractive index for helium than for argon, the resonance frequencies are very similar and the apparatus and procedure identical (section 5.1). Compared with the experiment with argon, the pressure measurement has been improved using a piston gauge section 5.2. The gas handling apparatus for helium gas is somewhat different than for argon (section 5.3). Finally, in a lighter gas, the acoustic resonances occur at higher frequency. Their measurement is described below.

4. Measurement of acoustic resonance frequencies

4.1. General principle

In a real gas in a resonator, the ideal gas equation 1 no longer holds true and the speed of sound c varies with pressure. We suppose its variation to be described by

$$c^2 = \frac{A_{-1}}{p} + A_0 + A_1 p + A_2 p^2 \quad (2)$$

where the coefficients A_{-1} , A_0 , A_1 and A_2 are independent of p . The terms proportional to p and p^2 are called the first and second virial terms and are related to van der Waals forces. The $1/p$ term is to account for energy exchange between gas and the resonator. For a detailed discussion of this equation see [27]. By performing measurements at different pressures and fitting the above equation to the data, one can extract the pressure-independent term A_0 and thereby calculate a value for the Boltzmann constant.

The speed of sound of acoustic standing waves c is related to resonance frequencies of a spherical resonator and the orders (n,l) of the radial and transverse modes and the radius of the resonator a whose measurement is described hereafter in subsection 5.1. Specifically,

$$c(p, T) = 2\pi a(p, T) \left[\frac{f_{nl}^A(p, T) + \Delta f_{nl}^A(p, T)}{Z_{nl}^A} \right] \quad (3)$$

where f_{nl}^A denotes the measured acoustic frequency, Δf_{nl}^A a correction to account for the effects of the cavity and non-ideal gas behaviour, and Z_{nl}^A is the eigenvalue of the mode (n, l) related to the zero of the corresponding Bessel function. The parentheses indicate that frequency and radius are functions of pressure p and temperature T . Residuals of fits of data for different acoustic modes to the polynomial of equation 2 are shown on the left-hand side of Figure 4.

Acoustic and microwave frequency measurements were performed simultaneously. From the microwave data, the average radius of the ellipsoidal resonator at T_{TPW} was

determined as a function of the pressure p . In this way, the Boltzmann constant is given by

$$k = \lim_{p \rightarrow 0} \left[\frac{3}{5} \frac{m}{T_{\text{TPW}}} \right] 4\pi^2 \langle a \rangle^2 \left\langle \frac{f_{nl}^A + \Delta f_{nl}^A}{Z_{nl}^A} \right\rangle^2 \quad (4)$$

where m is the atomic mass of the gas and the angular brackets denote averages. Since the average radius $\langle a \rangle$ is determined from microwave modes of order n', l' eigenvalue, $Z_{n'l'}^{EM}$ with measured frequencies $f_{n'l'}^{EM}$ and correction $\Delta f_{n'l'}^{EM}$ the value of k is deduced via

$$k = \lim_{p \rightarrow 0} \left[\frac{3}{5} \frac{mc_0^2}{T_{\text{TPW}}} \right] \left\langle \frac{Z_{n'l'}^{EM}}{f_{n'l'}^{EM} + \Delta f_{n'l'}^{EM}} \right\rangle^2 \left\langle \frac{f_{nl}^A + \Delta f_{nl}^A}{Z_{nl}^A} \right\rangle^2 \quad (5)$$

where c_0 the speed of light *in vacuo*. Note that in equations 4 and 5, the limit sought is not strictly that where $p \rightarrow 0$ (since there is a $1/p$ correction) but rather the value of k deduced from the pressure-independent term A_0 of a fit of c^2 versus p as described just above.

The acoustic resonances of modes (0,2) to (0,6) were determined for the helium-filled cavity for static pressures ranging from 0.12 MPa to 0.72 MPa at a temperature close to TPW. The mode (0,6) was the highest that could be studied given the frequency limit of the microphones, around 50 kHz. All the measurements were made at temperatures within ± 10 mK of 273.16K and frequencies were corrected using equation 10 of [19] to correspond to a temperature of 273.16 K exactly. For each mode, the frequency emitted by the source microphone was stepped quickly through the resonance (3 s per point) using 25 points for increasing frequency and 25 again for decreasing frequency to determine a rough value for the resonance frequency. The receiver microphone signal is amplified and sent to a lock-in detector. The final resonance curve of the mode was deduced from the average of data for increasing and decreasing frequency sweeps, as in [5]. Due to the greater thermal conductivity of helium compared with argon, the quality factor of the resonance is lower. We use equations 5.1 and 5.2 of [7] to analyse the data.

4.2. Corrections to measured frequencies

In order to deduce the speed of sound, and thereby the value of k , one needs to apply small corrections for physical effects, namely the thermal boundary layer, bulk dissipation, temperature discontinuity between He gas and the wall, ducts, acoustic transducers, and the non-spherical shape of the resonator. Each of these corrections can be estimated with the help of well-established models [5, 7, 19, 28, 29, 30]. During each acoustic cycle, heat exchange between the gas and the shell surrounding the cavity results in a thermo-acoustic boundary layer in the gas. Boundary layer corrections are the most important perturbation in this experiment (around 400 ppm). Unlike the case of argon, all the thermophysical properties for helium can be obtained by *ab initio* calculation [23]. Importantly, the input parameters to these expressions are known to

high accuracy. Using these and the thermal boundary layer correction equations can be found in [19], we deduce a correction with a lower relative uncertainty than for argon.

We applied Eq. 5.10 of [7] to the data of the isotherm and calculated, for each mode, the thermal accommodation coefficient h [31], obtaining three different values for the modes (0,4), (0,5) and (0,6) respectively 0.3913, 0.3929 and 0.3933; we take the thermal accommodation coefficient for the isotherm to be the average of these three values *i.e.* $h = 0.3926(10)$.

As has been explained in [7] the value of h near the shell resonance is affected by the pressure dependence of the shell response, which is why we use neither mode (0,2) nor (0,3) to measure it (*i.e.* because the shell resonance falls between them).

The value of the thermal accommodation coefficient is very sensitive to the adsorption condition of the solid surface and slightly sensitive to the surface roughness. Cochran and Irey [32] discuss the value of h for helium adsorbed on copper surfaces: on a clean copper surface with a roughness higher than the one of the present experiment ($Ra \simeq 1\text{-}4 \mu\text{m}$ *cf.* 2 nm here), h lies between 0.4 and 0.5.

We determined numerically the sensitivity of the value of k to a change in the value of the thermal conductivity λ and found

$$\frac{\Delta k}{k} = -5.46 \times 10^{-4} \left(\frac{\Delta \lambda}{\lambda} \right). \quad (6)$$

Since the relative uncertainty for the thermal conductivity λ is itself very small, (9.5×10^{-6} [23]), this correction has only a tiny effect on the uncertainty in the measurement of k .

Note that the shell effect here is very small compared with that in measurements using argon [7] which is due to the fact that the speed of sound in helium is over three times greater. In our previous Boltzmann constant measurement, with argon gas, the breathing resonance of the shell had a strong effect on all modes of resonance as shown by the figure 22 of [7]. In the case of helium, with the same cavity, the resonance frequencies used to determine k determination lie very far from the breathing resonance of the shell; although the breathing resonance lies between modes (0,2) and (0,3) it really affects only the latter, while modes (0,4), (0,5) and (0,6) are at much higher frequencies. Moreover, the correction due to shell vibration is a linear function of pressure, and can be taken into account completely via the coefficient A_1 defined in equation 2.

Contrary to the argon experiment [7], no effect of gas flow on the value of k described in [7] and [8] was discerned. This is obvious from figure 3 which shows speed-of sound versus flow rate (in units of sccm, defined in figure 3) for two separate runs at 650 kPa He in the resonator. The effect of the gas flow on the acoustic modes is related to the Mach number Ma , *i.e.* the ratio of the speed of the gas jet in the tube to that of the speed of sound. (see e.g.[33]) This effect becomes significant when Ma approaches the value $Ma \simeq 1$. In our case, not only is the speed of sound in helium three times greater than in argon, but also we have doubled the diameter of the inlet tube of the gas to decrease the flow effect.

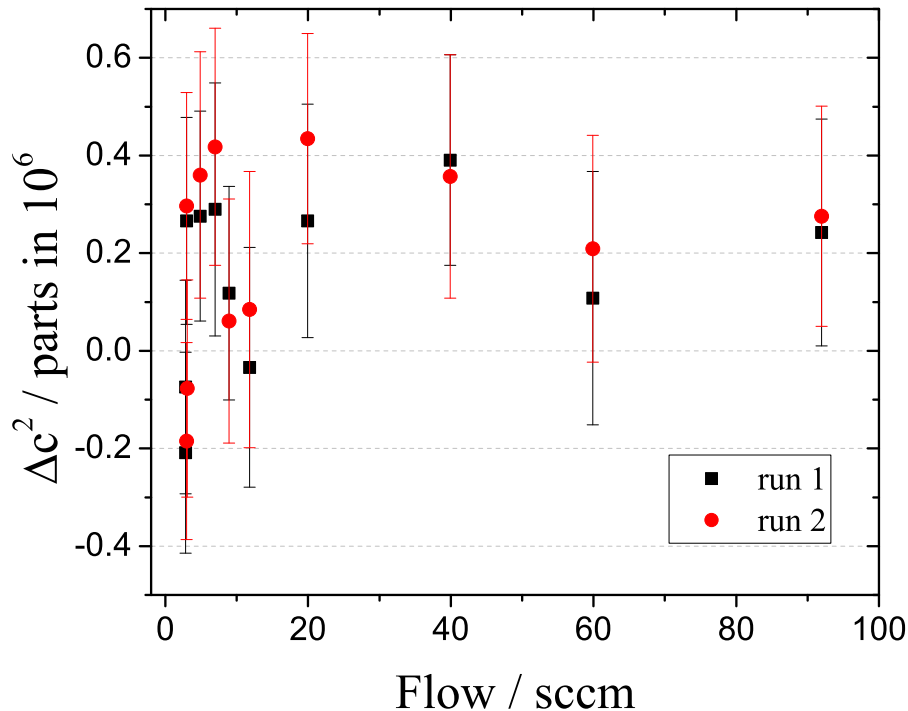

Figure 3. Change in squared sound velocity versus flow rate for He at 650 kPa. The unit sccm = "standard cubic centimetres per minute", corresponding to $1.666710^{-8} \text{ m}^3 \cdot \text{s}^{-1}$ in the International System of Units (SI). A volumetric flow of 1 sccm is defined as a flow of $1 \text{ cm}^3 \cdot \text{min}^{-1}$ of argon at a pressure 103 kPa and temperature 20 °C.

The last step of the data processing procedure was to correct all the data with the new estimate of h after which the corrected speed-of-sound data for each mode were fitted to the function of the pressure (equation 2). We stress that that no pressure-dependent weights were applied to the data *i.e.* all the results were deduced from *unweighted* fits.

The excess of the half-width (Figure 4) is the amount by which the measured half-width of a resonance exceeds that predicted by all of the effects discussed in this section. Excess half-widths thus provide a measurement of the size of the physical phenomena not included in our model for the acoustic resonator and are an order-of-magnitude estimate of how our imperfect understanding of resonator affects the result for k . The excess half-width of each mode is plotted on the right-hand side of Fig. 4. These graphs represent the difference between the measured and the calculated half-widths; no empirical parameters were fitted to make them. The following Figure 5 shows a measurement of the half-width of the (0,3) resonance as the cryostat is cooled. Because of the bump observed for $T \approx 273 \text{ K}$, no data from this mode was used to determine the value of k .

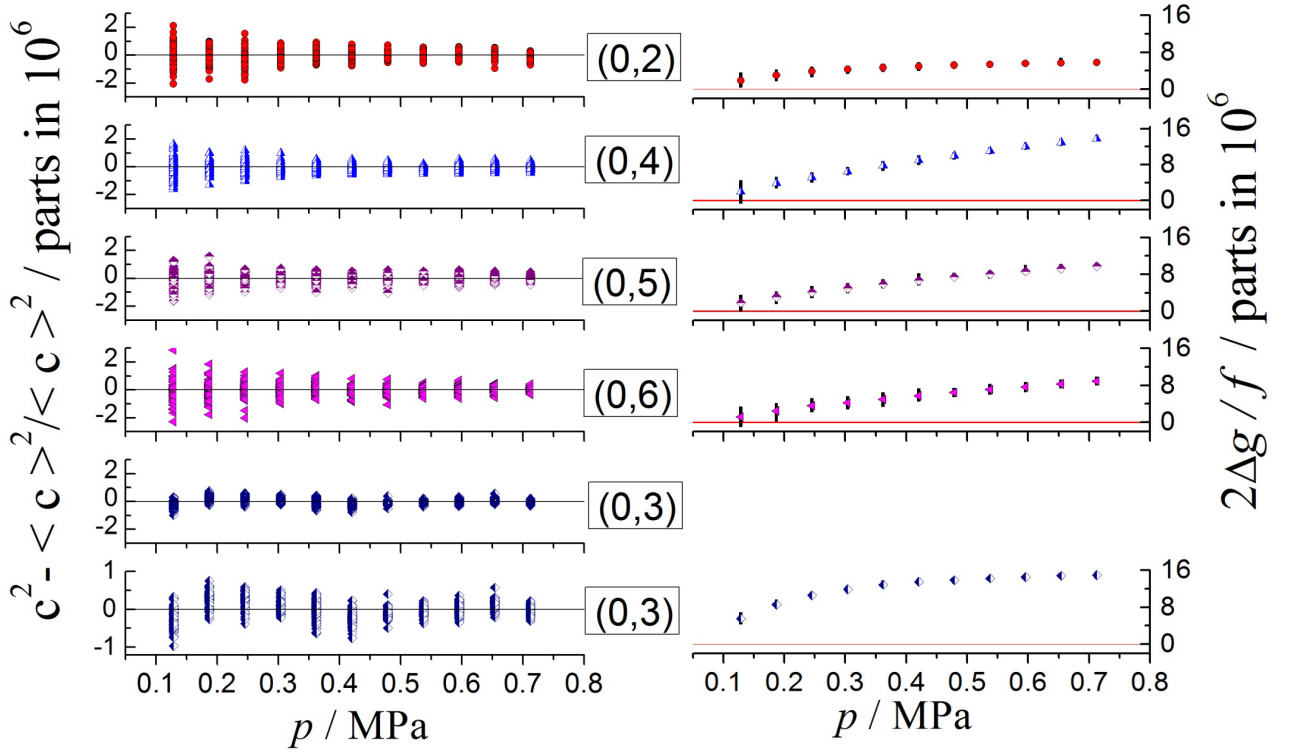

Figure 4. Residuals of squared sound velocities $(c^2 - \langle c^2 \rangle) / \langle c^2 \rangle$ (left) and doubled excess half-widths $2\Delta g/f$ (right) for the acoustic modes (0,2) to (0,6), as a function of the pressure p . The squared sound velocity is fitted to the polynomial of equation 2.

4.3. Uncertainty budget for acoustic measurements

The uncertainty budget is given in table 3.

Gillis *et al.* [36] tested the theory for the effects of gas ducts on the acoustic modes. They found agreement between their model and measurements at the level of 1% of the effects for long ducts and at the level of 10% for short ducts. To be conservative, we added to our uncertainty budget the effect of a factor 1.1 increase in the acoustic admittance of the ducts.

5. Measurement of resonator geometry, gas pressure, gas handling and thermometry

5.1. Determination of resonator radii via microwave resonances

The mechanical design of the copper resonator has already been described in detail for the case of a measurement of k with argon gas [7]. The inner shape is a triaxial ellipsoid defined by

$$\frac{x^2}{a_x^2} + \frac{y^2}{a_y^2} + \frac{z^2}{a_z^2} = 1 \quad (7)$$

where $a_x=49.950$ mm, $a_y=49.975$ mm and $a_z=50.000$ mm. Since, the diameters are thus close to 100 mm, an error in the diameter of 10 nm will affect the value of k at

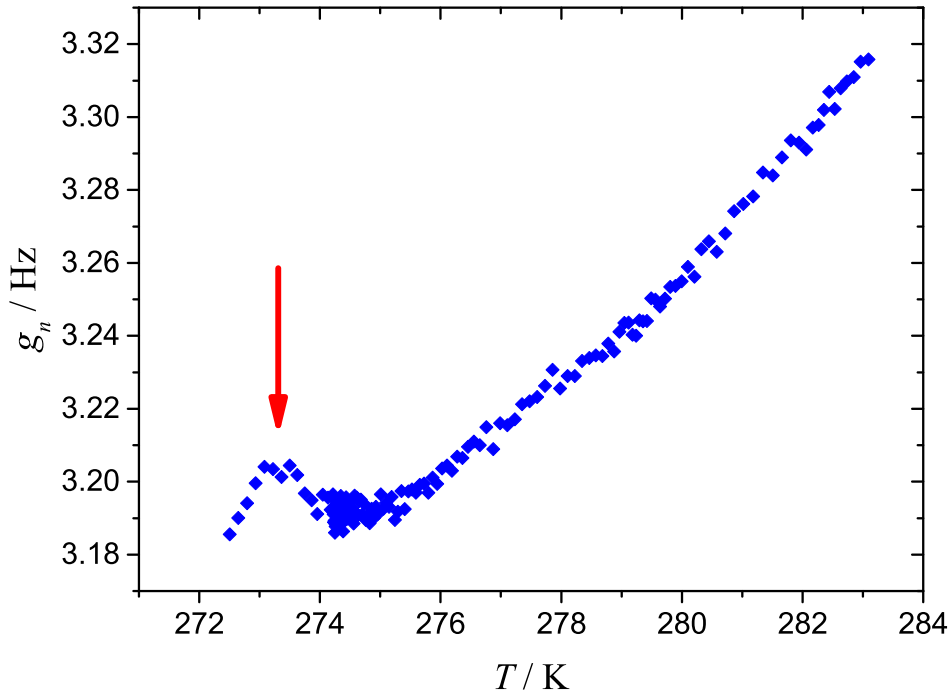

Figure 5. Measurement of the half width during a slow cooling of the thermostat. An unexpected perturbation is clearly observed at a temperature near 273 K. A spurious shell resonance was already observed in [34]. This figure underlines why no data from mode (0,3) is used to determine the value of k : the curve should not have this bump, which is due to another shell resonance coupled with the acoustic resonance.

a level of 2×10^{-7} . There are two ways to determine the dimensions of the resonator with a relative accuracy approaching 10^{-7} : pycnometry [5] and microwave resonance. We have chosen the latter since it allows a constant check of resonator size and can be performed simultaneously *in situ* with acoustic measurements but we also used an optimized CMM technique [37] to check the microwave determination of the dimensions prior to mounting assembly of the resonator.

To measure the dimensions, the same TE and TM modes are excited as in the experiment on argon [7] (see Figure 6). The values of measured microwave resonance frequencies depend on the product of the radius and the refractive index n which is a function of the type and amount of each gas and its temperature. In this way, accurate measurements of microwave frequencies are used not only to determine the mechanical dimensions and hence the acoustic wavelength but also, via the complex refractive index, to provide a cross-check of gas temperature, pressure and purity. Because of its simple atomic structure, the thermodynamic properties of helium gas can be calculated *ab initio* [23] at a level not possible for other noble gases. In particular, one can predict the refractive index of helium at a given temperature and pressure. In this experiment,

Table 3. Uncertainty budget for measurement of acoustic resonances. For conciseness, the relative standard uncertainty is denoted by u_{rel} .

Term	u_{rel} (10^{-6})	Note
Scatter among modes	0.45	Standard deviation of modes (0,2) and (0,4) to (0,6)
Thermal conductivity of helium	0.05	See § 2.2.2
Accommodation coefficient dispersion	0.14	Effect of a dispersion in h of 0.001
Shell perturbation	0.01	Change in result when a modified shell effect [35] is included or not <i>cf.</i> [7]
Tubing acoustic impedance	0.41	Change in result when impedance multiplied by 1.1
Pressure uncertainty	0.10	Offset of 13 Pa to allow for pressure uncertainty
Microphone impedance effect	0.05	Change in result when impedance multiplied by 1.1
Total (square root of quadratic sum)	0.63	

the temperature is constant but the pressure is varied for extrapolation to ideal gas behaviour. One can study the correlation of the actual refractive index as determined by microwave resonance and that predicted from the measurements of temperature and pressure. Furthermore, since trace amounts of water vapour will shift the value of the refractive index, microwave resonance provides a means of probing gas contamination.

5.2. Pressure measurement

To determine the Boltzmann constant from equation 1 one needs to extrapolate the value of the speed of sound to the ideal gas limit where the virial terms of eq. 2 vanish. In the current experiment, unlike the measurement with argon [7], the absolute value of the pressure is measured using a spinning piston gauge Ruska 2465-727 Gas Piston Gauge (Piston-cylinder serial number C662, calibrated by Fluke Calibration with respect to the NIST calibration chain [38]) and maintained constant using a servo loop. This approach turns out to have three advantages. The first is a factor of two increase in signal-to-noise for the measurements at the lowest pressures. The second is to allow one to predict the refractive index of helium gas and check it against microwave measurements, allowing for the compressibility of the resonator [17]. The final advantage is to alleviate the need to calibrate the pressure sensors located elsewhere in the gas handling system (see Figure 7). With the piston gauge, the uncertainty in the pressure, due mainly to the knowledge of the piston surface, is $u_p = 18 \times 10^{-6} \times p$, which corresponds to 13 Pa at the

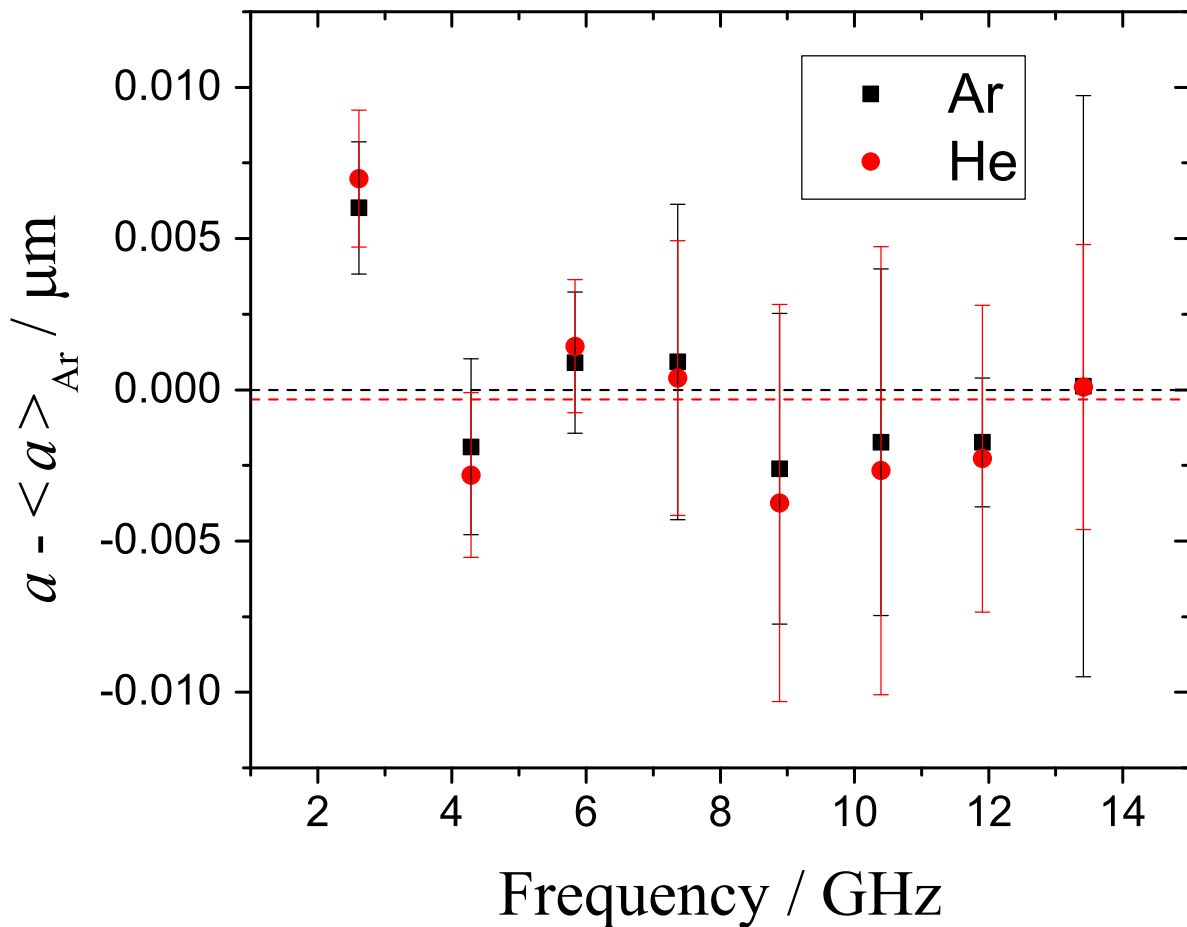

Figure 6. Measurement of the radius of the resonator filled with argon and helium gas using different microwave frequencies. In each case the value of the radius was extrapolated to zero pressure. The average value for He lies just below that for Ar but the difference is well below the level of uncertainty. $\langle a \rangle_{\text{Ar}}$ is the average over the different microwave frequency resonances when the cavity was filled with argon [7].

maximum pressure used in the experiment. An error of this size would shift the value of k by 0.10 ppm.

5.3. Gas handling

In order to counteract the effect of leaks, a flowing gas system is used (Figure 7). An advantage of using helium gas is that it can be purified after the source bottle by the use of a cold trap to remove all other gases. In the subsequent pipework and resonator itself, there might remain traces of other contaminants, notably water vapour, since it was chosen not to bake the system so as to avoid deformation.

In order to test and qualify the gas handling and purification system, we carried out two separate experiments. First the effectiveness of the liquid helium (LHe) cold trap was checked by using two different cold traps, each with a different design. The first one is just a cylinder of volume 4 cm³ directly in contact of the LHe. The second, of volume

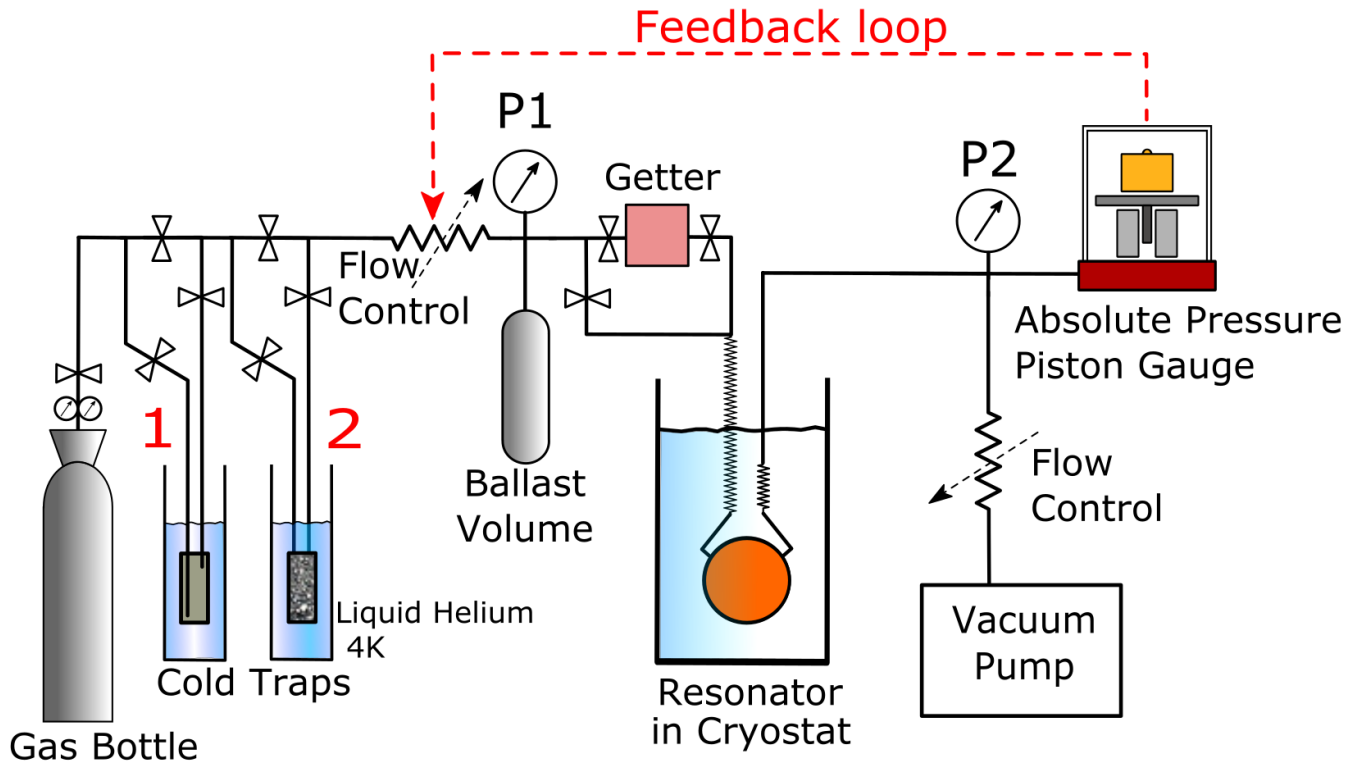

Figure 7. The gas-handling system. The gauges $P1$ and $P2$ are Digiquartz model 749 sensors. Cold trap 1 is a just U-tube while cold trap 2 contains charcoal.

10 cm^3 and filled with charcoal, has a much larger surface in contact with the liquid helium. The difference in results obtained using one or other of the traps (0.03 ppm in value of c^2) was indistinguishable at the noise level of the experiment ($\pm 0.25 \text{ ppm}$).

Although the Boltzmann constant was measured using gas from only a single bottle, the second auxiliary experiment was performed to study the effect of changing the gas bottle from ultra-pure helium 6N to one of the same nominal high purity (Alpha gas 2 from Air Liquide). Here only one cold trap (the smaller one) was used while the spherical resonator was kept at the same temperature and pressure (using the floating-piston-gauge-based regulation system). Since the cold trap should filter out everything but helium, the gas composition and speed of sound in the resonator should be identical. While the equilibrium values obtained from both bottles were indeed identical at the noise level (see figure 8), the squared velocity curves evolved differently. It might be that different bottles contain different amounts of ^3He because all other species should be removed by the cold trap. Since the origin of this difference (amounting to a relative shift of 0.44 ppm in k) is not understood, we include an uncertainty of 0.5 ppm under "Impurity" in Table 4. Yoshiki *et al.* (2005) [39] state that a bottle of ^4He gas should contain between 0.1 ppm and 1.0 ppm of the isotope ^3He and measured $0.14(8) \text{ ppm}$. As a conservative limit, we take a ratio of 0.65 ppm , an amount which would shift the value of k by 0.16 ppm as discussed by Moldover *et al.*[5] and include a correction of 0.16 with an uncertainty of 0.16 ppm in the uncertainty budget (Table 4).

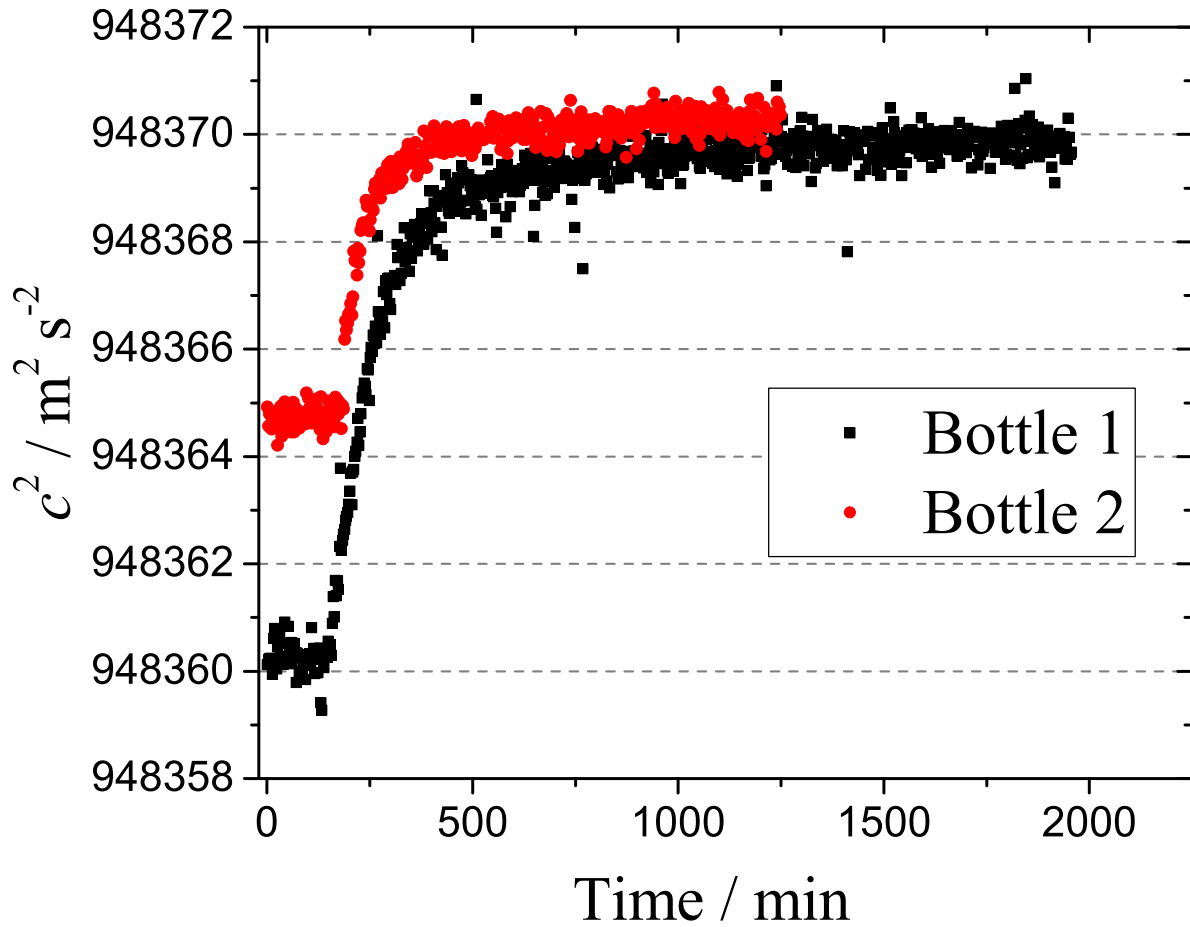

Figure 8. Squared speed of sound as a function of time for He from two different gas bottles of nominally identical purity, filtered using a helium-cooled trap.

Table 4. Uncertainty budget for measurement of molar mass and gas purity resonances. The relative standard uncertainty is denoted by u_r .

Term	u_r (10^{-6})	Note
$^3\text{He}/^4\text{He}$ ratio	0.16	See text
Coldtrap effectiveness	0.03	See text
Impurity	0.50	Estimate made with two bottles
Total (square root of quadratic sum)	0.53	

5.4. Thermometry

5.4.1. General considerations In early determinations of k by acoustic thermometry, a cylindrical resonator was inserted within a triple point cell [40]. This is not possible with the present, ellipsoidal resonator which is instead housed in a heat bath maintained at a temperature close to TPW. The temperature of the resonator is measured using four CSPRTs from different manufacturers. Note that three different brands of CSPRT were used *i.e.* three different technologies. (Data from a fourth one, of another make, was not used due to its instability, as discussed in [7]). Their calibration and the thermal mapping of the resonator were detailed in [7]. The heat bath is the same as that employed in the work on argon but it is used in a slightly different way, as described above in section 3. Note that an uncertainty in T of 0.273 mK corresponds to a relative uncertainty of 10^{-6} in the measurement of k . After recalibration of thermometers we confirm the calibration uncertainty of 0.1 mK given in [7] as justified below.

5.4.2. Stability and recalibration of thermometers The CSPRTs were calibrated at the triple point of water prior to the Boltzmann constant determination in argon described in [7]. As a reminder, their serial numbers are "1551", "1825277" and "HS135". Since measurements using helium were started immediately after those with argon, the CSPRTs were not recalibrated between the two experiments. However, their stability was monitored by crosscheck measurements performed on isotherms when the resonator was filled with helium, and no significant deviations were observed within the measurement uncertainties. After the completion of the whole Boltzmann constant experiment with helium, the cryostat was opened and the CSPRTs were recalibrated at TPW, using the same cell as previously, in order to assess their stability. New calibrations at the triple point of water showed that, with respect to the calibration in [7]:

- CSPRT 1551 deviated by 0.10(16) mK ;
- CSPRT 1825277 deviated by -0.03(09) mK;
- CSPRT HS135 deviated by -0.19(07) mK.

Figure 9 shows the difference between the resonator temperature measured on an isotherm by the CSPRTs referred to their original calibration [7] (grey), and the same temperature referred to the new calibration (black circles). Average temperatures (grey and black lines) differ by less than 0.04 mK. The new calibration values are thus compatible with the previous ones in [7] within their respective standard uncertainties. Given that the average temperature of the resonator, calculated from the three CSPRT measurements according to equation (3.9) in [7], differed by less than 0.04 mK from the original calibration, the values from [7] rather than the new ones are used here.

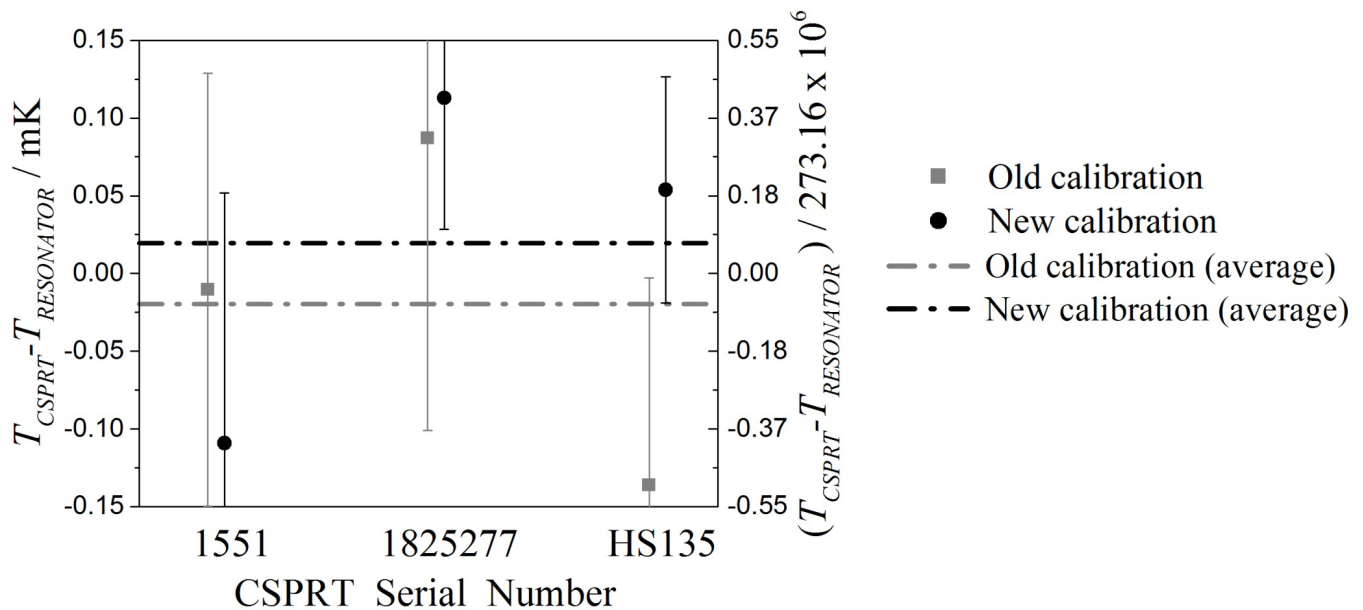

Figure 9. Calibration of the 25 Ω platinum resistance thermometers before the measurement of k with argon [7] and after the present one using helium. The new average lies above the old one by less than 0.04 mK.

6. Results and conclusion

6.1. Results

Figure 10 shows final values of k determined by four modes plotted as fractional deviations from the CODATA 2010 value. The uncertainty bars represent the uncertainty of the parameter A_0 resulting from each second-order fitting function given in Eq. 2, the dashed line is the mean value of k found in this work and the grey areas represent the uncertainty. The average over the modes was unweighted. The data will be posted on internet [41].

Thermometry has been carried out at a level of 0.3 ppm limited by the accuracy of water triple point cells. This represents a baseline for any determination of k . The same resonator was used as for the previous measurement with argon gas and its dimensions measured with comparable accuracy in both cases by microwave resonance. The microwave resonances are essentially the same when the resonator is filled with either gas. By contrast, whereas with argon isotopic composition and gas purity was the dominant source of uncertainty, with helium, acoustic boundary layer corrections give rise to the largest term.

As shown by Figure 1 the present measurement lies in agreement with the result of our previous determination using argon gas and most other measurements elsewhere that used either acoustic gas thermometry or other techniques.

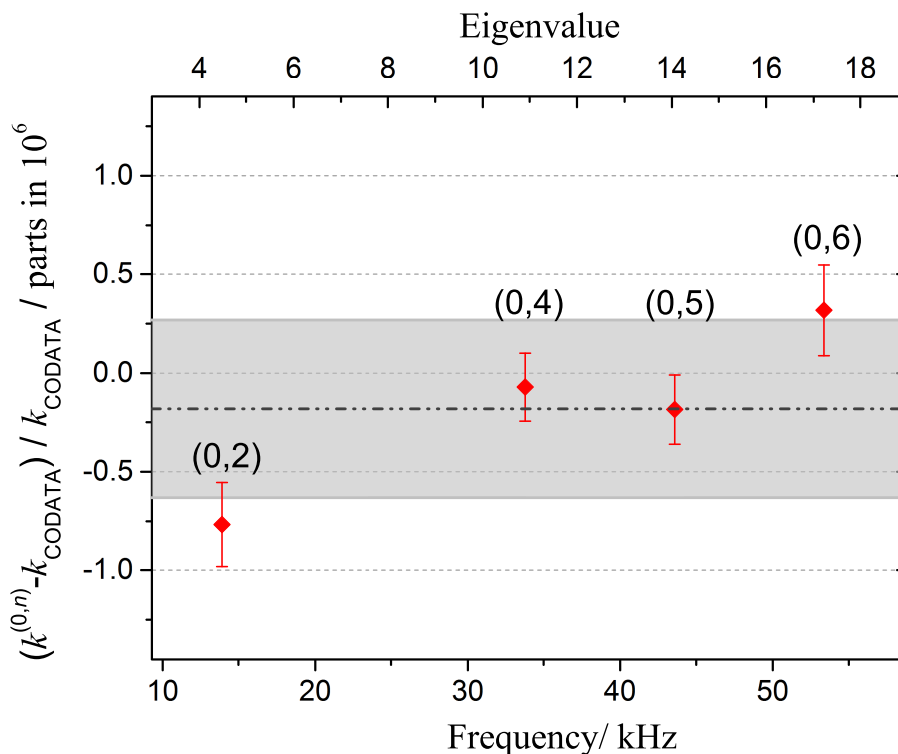

Figure 10. Final values of k determined by four modes plotted as fractional deviations from the CODATA 2010 value. The uncertainty bars represent the uncertainty of the parameter A_0 resulting from each fit and the grey areas represent the uncertainty.

6.2. Conclusion

This article has described a determination of the Boltzmann constant k by acoustic thermometry in helium gas using a quasi-spherical resonator. It is the first measurement of this kind with a relative uncertainty below 2×10^{-6} using helium instead of argon. Another peculiarity of this experiment is that it is performed in quasi-adiabatic thermal conditions, instead of standard, constant heat-flux conditions. As well as providing a fresh measurement of a fundamental constant, this experiment has served as a further proof of principle of the use of an acoustic thermometer with a triaxial ellipsoidal cavity. To reduce the relative perturbation introduced on the surface of the resonator by the acoustic transducers, we now have built a scaled-up 3 l resonator [42] for measurements with argon and subsequently with helium gas.

Acknowledgments

The authors gratefully acknowledge first and foremost a longstanding collaboration with James Mehl and Michael Moldover without whose input this work would not have developed. We acknowledge helpful discussions with colleagues in our own institute and elsewhere, especially, Anne-Marie Bruneau, Michel Bruneau, Roberto Gavioso, Keith Gillis, Cécile Guianvarc'h, , Gavin Sutton, Robin Underwood and Jintao Zhang. In

addition these results would not have been obtained without the support of Terry Quinn, Françoise Le Frious, Florian Platel and Yves Hermier. We gratefully acknowledge funding from the French National Research Agency ANR and the EURAMET Joint Research Project which receives funding from the European Union's Seventh Framework programme, iMERAPlus, under Grant Agreement N^o. 217257. Finally, the authors are indebted to the anonymous referees whose constructive criticism has improved the manuscript immeasurably.

References

- [1] M. Mills, P.J. Mohr, T.J. Quinn, B.N. Taylor, and E.R. Williams. Redefinition of the kilogram, ampere, kelvin and mole: a proposed approach to implementing CIPM recommendation 1 (CI-2005). *Metrologia*, 43:227–246, 2006.
- [2] G.F. Strouse and M. Zhao. The Impact of Isotopic Concentration, Impurities, and Cell Aging on the Water Triple-Point Temperature. *Int. J. Thermophys.*, 28:1913–1922, 2007.
- [3] B.W. Petley. *The Fundamental Physical Constants and the Frontier of Measurement*. Adam Hilger, 1985.
- [4] A.R. Colclough. Methods for the determination of the gas constant. In B.N. Taylor and W.D. Phillips, editors, *Precision Measurement and fundamental constants 2 : Proceedings of the Second International Conference held at the National Bureau of Standards, Gaithersburg, MD, June 8-12, 1981 NBS Special publication 617*, pages 263–275. US Government printing office, Washington D.C., 1984. 696 pages.
- [5] Moldover M.R., Trussler J.P.M., Edwards T.J., Mehl J.B., and Davis R.S. Measurement of the universal gas constant R using a spherical acoustic resonator. *J. Res. Natl. Bur. Stand. (US)*, 93(2):85–144, March-April 1988.
- [6] Gavioso R.M., Benedetto G., Guilano Albo P.A., Madonna Ripa D., Merlone A., Guianvarch C., Moro F., and Cuccaro R. A determination of the Boltzmann constant from speed of sound measurements in helium at a single thermodynamic state. *Metrologia*, 47:387–409, June 2010. INRIM.
- [7] Pitre L., Sparasci F., Truong D., Risehari L., Guillou A., and Himbert M. Measurement of the Boltzmann constant k_B using a quasi-spherical acoustic resonator. *Int. J. Thermophys.*, 32(9):1825 – 1866, 2011.
- [8] M. de Podesta, R. Underwood, G. Sutton, P. Morantz, P. Harris, D.F. Mark, F.M. Stuart, G. Vargha, and G. Machin. A low uncertainty measurement of the Boltzmann constant. *Metrologia*, 50(4):354–376, July 2013.
- [9] C. Gaiser, B. Fellmuth, and N. Haft. Primary Dielectric-Constant Gas Thermometry in the Range from 2.4 K to 26 K at PTB. *Int. J. Thermophys.*, 29:18–30, 2008. PTB 1.
- [10] B. Fellmuth, J. Fischer, C. Gaiser, O. Jusko, T. Priruenrom, W. Sabuga, and T. Zandt. Determination of the Boltzmann constant by dielectric-constant gas thermometry. *Metrologia*, 48(5):382–390, 2011. PTB 2.
- [11] C. Gaiser, T. Zandt, B. Fellmuth, J. Fischer, O. Jusko, and W. Sabuga. Improved determination of the Boltzmann constant by dielectric-constant gas thermometry. *Metrologia*, 50:L7–L11, 2013. PTB 3.
- [12] S.P. Benz, A. Pollarolo, J. Qu, H. Rogalla, C. Urano, W.L. Tew, P.D. Dresselhaus, and D.R. White. An electronic measurement of the Boltzmann constant. *Metrologia*, 48(3):142–153, 2011. JNT NIST.
- [13] K. Djerroud, C. Lemarchand, A. Gauguet, C. Daussy, S. Briauudeau, D. Darquié, O. Lopez, A. Amy-Klein, C. Chardonnet, and C.J. Bordé. Measurement of the Boltzmann constant by the Doppler broadening technique at a 3.8×10^{-5} accuracy level. *C.R. Physique*, 10:883–893,

2009. Subsequent publications by the same group cite a reduced uncertainty but give no value for the Boltzmann constant.
- [14] J. Fischer. *Comité consultatif des températures*. Working group 4. Private communication.
 - [15] P.J. Mohr, B.N. Taylor, and D.B. Newell. CODATA recommended values of the fundamental physical constants: 2010. *Rev. Mod. Phys.*, 84(4):1527–1605, 2012.
 - [16] L. Pitre, C. Guianvarc’h, F. Sparasci, A. Guillou, D. Truong, Y. Hermier, and M.E. Himbert. An improved acoustic method for the determination of the Boltzmann constant at LNE-INM/CNAM. *C. R. Phys.*, 10:835–848, 2009. LNE 1.
 - [17] J.W. Schmidt, R.M. Gavioso, E.F. May, and M.R. Moldover. Polarizability of Helium and Gas Metrology. *Phys Rev Lett.*, 98:254504–1 – 254504–4, 2007. RIGT NIST.
 - [18] A.R. Colclough, T.J. Quinn, and T.R.D. Chandler. An acoustic redetermination of the gas constant. *Proc. R. Soc. London A*, 368:125–139, 1979. NPL 1.
 - [19] G. Sutton, R. Underwood, L. Pitre, M. de Podesta, and S. Valkiers. Acoustic Resonator Experiments at the Triple Point of Water: First Results for the Boltzmann Constant and Remaining Challenges. *Int. J. Thermophys.*, 31:1310–1346, 2010.
 - [20] J.T. Zhang, H. Lin, J.P. Sun, X.J. Feng, K.A. Gillis, and M.R. Moldover. Cylindrical acoustic resonator for the re-determination of the Boltzmann constant. *Int. J. Thermophys.*, 31:1273–93, 2010. NIM-NIST 1.
 - [21] J.T. Zhang, H. Lin, X.J. Feng, J.P. Sun, K.A. Gillis, M.R. Moldover, and Y.Y. Duan. Progress Toward Redetermining the Boltzmann Constant with a Fixed-Path-Length Cylindrical Resonator. *Int. J. Thermophys.* (2011), 32:12971329, 2011. NIM-NIST 2.
 - [22] M. de Podesta, I. Yang I, D.F. Mark, R. Underwood, G. Sutton, and G. Machin. Correction of NPL-2013 estimate of the Boltzmann constant for argon isotopic composition and thermal conductivity. Submitted to *Metrologia*.
 - [23] W. Cencek, M. Przybytek, J. Komasa, J.B. Mehl, B. Jeziorski, and K. Szalewicz. Effects of adiabatic, relativistic, and quantum electrodynamics interactions on the pair potential and thermophysical properties of helium. *J. Chem. Phys.*, 136(22):224303: 1–32, 2012.
 - [24] M. Berglund and M.E. Wieser. Isotopic compositions of the elements 2009 (IUPAC Technical Report). *Pure Appl. Chem.*, 83(2):397–410, 2011.
 - [25] D.A. Shea and D. Morgan. The Helium-3 shortage: Supply, demand and options for Congress, December 2011. CRS Report for Congress, R41419.
 - [26] H. Lin, X.J. Feng, K. Gillis, M.R. Moldover, J.T. Zhang, J.P. Sun, and Y.Y. Duan. Improved determination of the Boltzmann constant using a single, fixed-length cylindrical cavity. *Metrologia*, 50(5):417–432, 2013.
 - [27] M.R. Moldover, R.M. Gavioso, J.B. Mehl, L. Pitre, M. de Podesta, and J.T. Zhang. Acoustic gas thermometry. *Metrologia*, 51:R1–R19, 2014.
 - [28] J.B. Mehl, M.R. Moldover, and L. Pitre. Designing quasi-spherical resonators for acoustic thermometry. *Metrologia*, 41:295–304, 2004.
 - [29] C. Guianvarc’h, L. Pitre, M. Bruneau, and A.-M. Bruneau. Acoustic field in a quasi-spherical resonator : unified perturbation model. *J. Acoust. Soc. Am.*, 125:1416–1425, 2009.
 - [30] C. Guianvarc’h, R.M. Gavioso, G. Benedetto, L. Pitre, and M. Bruneau. Characterization of condenser microphones under different environmental conditions for accurate speed of sound measurements with acoustic resonators. *Rev. Sci. Instrum.*, 80:074901, 2009.
 - [31] M.B. Ewing, M.L. McGlashan, and J.P.M. Trusler. The Temperature-Jump Effect and the Theory of the Thermal Boundary Layer for a Spherical Resonator. Speeds of Sound in Argon at 273.16 K. *Metrologia*, 22:93–102, 1986.
 - [32] M.E. Cochran and R.K. Irey. Thermal Accommodation Coefficients of Helium and Nitrogen on Copper Surfaces. *Advances in Cryogenic Engineering (1972)*, 17:456–461, 1972.
 - [33] M. Bruneau. *Manual d’Acoustique Fondamentale*. Hermes Science Publications, Paris, 1998. In French.
 - [34] D. Truong, F. Sparasci, E. Foltête, M. Ouisse, and L. Pitre. Measuring Shell Resonances of

- Spherical Acoustic Resonators. *Int. J. Thermophys.*, 32:427–440, 2011.
- [35] J.B. Mehl. Spherical acoustic resonator: Effects of shell motion. *J. Acoust. Soc. Am.*, 78(2):782–788, 1985.
- [36] K.A. Gillis, H. Lin, and M.R. Moldover. Perturbations from ducts on the modes of acoustic thermometers. *J. Res. Nat. Inst. Stand. Technol.*, 114:26385, 2009.
- [37] M. de Podesta, E.F. May, J.B. Mehl, L. Pitre, R.M. Gavioso, G. Benedetto, P.A. Giuliano Albo, D. Truong, and D. Flack. Characterization of the volume and shape of quasi-spherical resonators using coordinate measurement machines. *Metrologia*, 47:588–604, 2010.
- [38] Fluke Calibration, 4765 East Beautiful Lane, Phoenix AZ 85044 USA. Calibration report number 1500136254 dated July 12 2012.
- [39] H. Yoshiki, H. Nakai, and E. Gutmiedl. A new superleak to remove He³ for UCN experiments. *Cryogenics*, 45:399–403, 2005.
- [40] T.J. Quinn, A.R. Colclough, and T.R.D. Chandler. A New Determination of the Gas Constant by an Acoustic Technique. In J.H. Sanders and A.H. Wapstra, editors, *Atomic Masses and Fundamental Constants*, volume 5, pages 608–614. Plenum Press, New York, 1976.
- [41] <http://lcm.cnam.fr/thermometrie/kb.helium.2014.zip>.
- [42] L. Pitre, F. Sparasci, L. Risehari, C. Guianvarc’h, M.D. Plimmer, and M.E. Himbert. Improved apparatus to determine the Boltzmann constant using a large quasi-spherical acoustic resonator. CPEM2014 Conference on Electromagnetic Measurements, Rio de Janeiro, Brazil, 24-29 August 2014. Poster 71 in session MO-P112.